



# YOUTH COMPETITIVE

## SENIOR AMATEUR

BY TOM SAUDER

Print & Go Practice Plans and Drills

- advanced skills and tactics
- an essential guide for all youth soccer coaches



## TABLE OF CONTENTS

Acknowledgement	4
Introduction	5
Our Philosophy	6
Usage Recommendations	7
Practices Summary Matrix	8
Season Practice Sequences	9
Print & Go Practices	10
· # 1 Fast Break Attack #1	11
· # 2 Flank Attack, Scoring	12
· # 3 Defending	13
· # 4 Passing, Anticipation, Transition	14
· # 5 Scoring, Transition Play	15
· # 6 Ball Control, Flank Attack	16
· # 7 Scoring Goals, Flank Attack	17
· # 8 Crossing Balls, Scoring	18
· # 9 Defending	19
· #10 Scoring, Flank Attack #2	20
Warm Ups	21
· # 1 Passing, Headers, 1v1	22
· # 2 Dribbling, 1v1	23
· # 3 Dribbling, agility	24
· # 4 Anticipation, Passing	25
· # 5 Dribbling & Shooting	26
· # 6 Dribbling, Crossing	27
· # 7 Passing	28
· # 8 Agility, Ball Control, Fun	29
· # 9 Circuit	30
· #10 Circuit with Passing and Control	31
Technical Skills	32
· # 1 3v2 with shot on goal	33
· # 2 2v2 give and go with shot on goal	34
· # 3 1v1, shot on goal	35
· # 4 Transition Play	36
· # 5 1v1	37
· # 6 4v4 Flank Attack	38
· # 7 4v4 in small area	39
· # 8 Two touch shooting	40
· # 9 1v2 Defending	41
· #10 Crossing and 2v1	42

## TABLE OF CONTENTS

<u>Fitness Drills</u>	<u>43</u>
· # 1 Pass and Sprint	44
· # 2 6v3	45
· # 3 Agility/Sprint	46
· # 4 Receive-Pass-Turn	47
· # 5 Reaction Sprint and 1v1	48
· # 6 3v1 with crossing	49
· # 7 Sprint and Score	50
· # 8 Dribble and Cross	51
· # 9 Sprint and 1v1	52
· #10 4v4 in penalty box with crossing	53
<u>Tactical Drills</u>	<u>54</u>
· # 1 3v3 with Target Player	55
· # 2 7v7 into four corners	56
· # 3 4+2 v 2+4	57
· # 4 6v4 Pressing and Counterattack	58
· # 5 Transition Play	59
· # 6 6v6 Flank Attack	60
· # 7 4v4+N Crossing	61
· # 8 Crossing	62
· # 9 4v3+GK	63
· #10 4v4 with 3 Groups	64
<u>Scrimmages</u>	<u>65</u>
· # 1 6v6 ½ Field	66
· # 2 Flank Attack	67
· # 3 1v1 Defending in 7v7	68
· # 4 7v7 with GK Transition Play	69
· # 5 Transition Play	70
· # 6 4v4 plus 3v2	71
· # 7 7v7 Flank Attack	72
· # 8 7v7 with Crossing	73
· # 9 8v8	74
· #10 5v4	75

## ACKNOWLEDGEMENTS

This book is dedicated to all coaches, players, parents and officials without whose passion for soccer the greatest game in the world could not exist.

We thank all the teams, players and coaches that have participated in developing the practice sessions and used them on the field them to make sure they work.

## Introduction

The idea for Print & Go practices came from a recognition that something was missing for soccer coaches amongst all the training materials and resources available.

No doubt you have heard that a coach must have a practice plan when going to run a practice. If you are like most coaches, you probably have books and videos full of drills and practice ideas. If you are like most coaches, you also rush from work to the practice field desperately trying to write a practice plan in your head (hopefully not on paper while driving), organizing and visualizing drills and things to say. Maybe you even brought some books or photocopies of drills with you. Maybe you even roughed out a plan the night before on a piece of paper. No matter what, you either spent significant time researching and writing or significant time scrambling.

What about the next practice? What about a season plan? What about the team's needs and focus? Fitness training: yes or no? During practice or separate sessions? Scrimmages? Speed and mental training? Where are the drills for that? How about flexibility? Any difference between age groups?

To help you focus your time on deciding what is important for your team to work on we thought it would be a good idea to do the research and the writing for you. So we have developed a set of 10 complete practice sessions and a tool to develop hundreds of additional sessions. All you need to do is to decide on a focus for the season and a theme for each practice. The printed material is supplemented by pictures of stretches and moves and by the tips published on our website [www.soccerpracticebooks.com](http://www.soccerpracticebooks.com).

This is the second book in our series of Print & Go practice plans.

We recommend this set for competitive youth teams (travel teams, representative teams, regional teams, state/provincial teams, etc.), ages 13 and up, as well as for senior level amateur teams at all levels of competitiveness.

These practices and drills have been run with competitive 13 year old boys and 15 year old girls teams as well as with College teams.

We hope you will enjoy your season.

## Our Philosophy

Practices need to be fun for players and coaches. Drills must be interesting and vary across skills, tactics, strategies, mental and physical fitness and team building.

Players need to be busy with a ball at all times to maximize the number of touches they get with the ball.

Practices must flow and time must not be wasted by the coach setting up or thinking about drills.

Practices and drills must have a purpose.

We suggest you schedule 2 hours for the practice and ask your players to be ready to warm up at the scheduled time. A break is suggested after the fitness drill. Any delay in starting will cut into the all important and popular scrimmage time.

We suggest that each practice starts with a brief meeting between coaches and players in which the theme of the practice is communicated to the players.

Then start with a warm up. You will notice that our warm-ups already incorporate the theme of the practice, lots of ball work, fitness and thinking exercises in a purely soccer way. No repetitive running, not many exercises without a ball and if so, then they are fun and challenging.

We have cushioned the fitness section between technical and tactical drills. The reason is that we want players to be properly warmed up for skill work, but then challenge their stamina and mind by requiring tactical skills after fitness work.

End with a scrimmage and feel free to adapt them or change them to suit your team's needs.

After the practice, have a quick meeting again for going over the practice briefly, invite comments from the players, congratulate them on their effort and improvement and make any announcements regarding upcoming events.

During the drills, be patient. Observe and intervene only when needed. Keep your comments positive, to the point and brief. Speak loudly and clearly. It is better to demonstrate a drill or a concept than to give a speech. Never yell at a player or use derogatory language.

## Print & Go Practices – Usage Recommendations

We have developed a matrix for the 10 sessions showing the focus of the practice and of each of the drills in the practice. Please study the matrix to become familiar with the content of each session and drill.

On the matrix page is a box suggesting various ways to sequence these sessions. Chose the emphasis for your next 10 practices (which could be a season or pre-season) and study the sequence suggested. Of course, you are free to develop your own sequence. Refer to the individual practice sheets or the individual drill sheets for a better understanding. Write comments on the drill sheets.

We suggest you visualize the drills to make sure you understand how they will flow. If necessary, set them up in your living room and walk through them.

Keep a clean copy of the book at home and put the pages you take to the practice with you in clear plastic sheet protectors to protect them from water or other disturbances (you know what can happen to papers).

We encourage you to create your own practice plans by mixing and matching the drills.

We recommend that you stick with our general practice philosophy and at a minimum suggest you start with a warm-up and end with a scrimmage. In between, you can design whichever way. If your team needs 4 fitness sessions and no technical/tactical work- go for it. You want to work three shooting related sessions- they are ready to go.

This book is provided or sold on an as is basis without warranties of any kind, express or implied, including but not limited to those of title, merchantability, fitness for a particular purpose, or non infringement, or any warranty arising from a course of dealing, usage, or trade practice. The user assumes all responsibility or risk for the use of this practice book and the drills. contained therein. Under no circumstances, including negligence, shall any of the parties involved in creating, maintaining, or supplying information used in this practice book and the drills contained therein be liable for any direct, indirect, incidental, special, or consequential damages, or lost profits that result from the use or inability to use this soccer practice book and its soccer drills.

Practice #	Practice Focus	Warm-Up Focus	Technical Drill	Fitness Focus	Tactical Drill	Scrimmage Focus
1	Fast Break Attack	Passing Headers	3v2 with shot on goal pass and sprint	3v3 with target player	6+GK v 6 half field regular goal+2wide goals	
2	Flank Attack Scoring	Dribbling 1v1	2v2 give and go with shot on goal	6v3 in penalty area regular+2 small goals	cross dribble and cross	
3	Defending	Dribbling Agility	1v1 with shot on goal	Agility Sprint	zone defending 4+2 v 2+4	7v7+GK setting up 1v1 on goal
4	Passing Anticipation Transition	Anticipation Passing	Transition Play 4v4 on 2 goals	Receive-Pass-Turn	6v4 Pressing Counterattack	7v7 with GK Transition Play
5	Scoring Transition	Dribbling Shooting	2v2 with GK plays as 2x 1v1	Reaction sprint and 1v1	3 v 3 penetration passing and shooting play in one half and score in other half	6v6 +GK
6	Flank attack Ball Control	Dribble Crossing	4v4 + 4 neutrals with GK on 2 goals flank attack	3v1 with crossing	6v6 + GK flank attack	4v4 + 2x 3v2 with GK Full size goals
7	Scoring Goals Flank attack	Passing	4v4 with GK score on either goal in small area	Sprint and score kick, head	4v4 with N crossing 2 teams on large goal score on either goal in penalty area after cross	7v7 full field
8	Crossing Balls Scoring	Agility Ball Control Fun	Two touch Shooting	Dribble and cross sprint back	Crossing from spot and after pass. with/without challenge	7v7 +GK with crossing
9	Defending	Circuit Dribble, pass, shoot	1v2 defending	Sprint and 1v1	4v3 +GK 1 large, 2 small goals defend small goals	8 v 8
10	Scoring Goals Flank attack #2	Circuit Passing & Control	Crossing and 2v1	4v4 in penalty box with crosses	4v4 with GK 3 groups	5 v 4+GK



## Practice sequence Suggestions

### Coaching Emphasis

### Practice Sequence

Pre-Season	3-4-2-5-1-8-7-9-6-10
Season Build	9-3-1-8-4-2-6-7-10-5
Scoring	5-7-8-10-6-2-1-3-9-4
Defending	9-3-2-10-1-4-6-7-5-8
Midfield	1-4-10-2-5-6-9-3-7-8
Fitness Build	4-5-9-10-3-2-1-7-8-6

# Youth Competitive

## Print & Go

### Practice Plans



# COMPETITIVE SOCCER PRACTICE # 1

Practice Focus: Fast Break Attack # 1

Time: 2 hrs

## Warm-Up: Passing, Headers, 1v1 (30 min)

1. Set up 10-15 (2 m) wide goals. In partners, freely move around passing ball through all goals.
2. Runner's stretch (hold 20 sec. each side, 3 reps/side)
3. Groups of three players form triangles standing 5 m apart from each other.  
Player 1 throws to player 2, who heads to player 3. Player 3 throws to P1 who heads to P2, etc.
4. Quad stretch (hold 20 sec. each side, 3 reps/side).
5. 4 pairs play 1v1 in a 25m x 25m grid with two full size goals and goalkeepers.  
Two neutral players in the grid can be used by any other pair.  
Shots on goal must follow a give & go with one of the neutral players.
6. Hamstring stretch (hold 20 sec. each side, 3 reps/side).
7. Same set up as in step # 5.  
Four players are on diagonally opposite sides of the goals.  
- X's start with a ball each. First player X starts to attack opposite goal. O challenges X and both now play 1v1 on the same goal.  
- after all X's have started, O's start with ball and attack goal.
8. Heel stretch (hold 20 sec. each side, 3 reps/side).

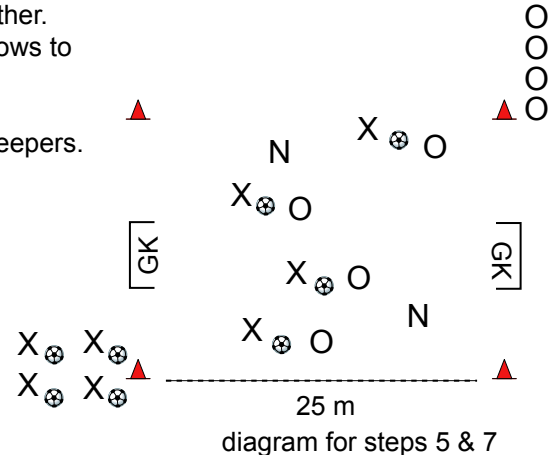

## Technical Skill: 3v2 with Shot on Goal (20 min.)

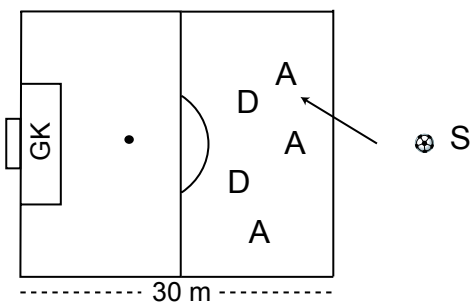

Server (S) plays ball to one of the attackers (A) outside the penalty area. Attackers play 3v2 and try to combine to get a shot on goal and score. If defenders win the ball, they must play it back out to server.

Set up two groups or more depending on number of players.

Play 5 minute games and rotate defenders and attackers.

## Fitness Drill: Pass and Sprint (15 min.)

1. X's pass the ball back and forth to each other.
2. At random, one X passes ball slightly forward.
3. The pass is the command for the two O's to sprint around X's to win the ball and play 1v1 on goal.

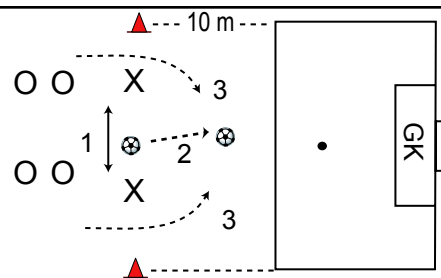

## Tactical Drill: 3v3 with Target Player (20 min.)

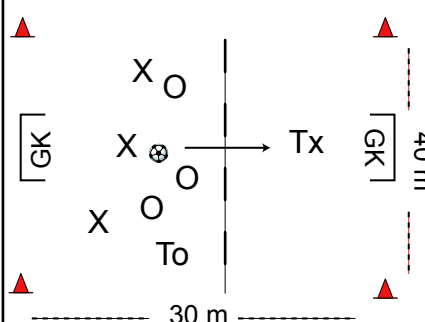

3 X v 3 O each team with target player To and Tx.

To and Tx stay in attacking half.

1 point for goal, 2 pts for goal after give & go with target player.

## Scrimmage: 6v6 - 1/2 field (30 min.)

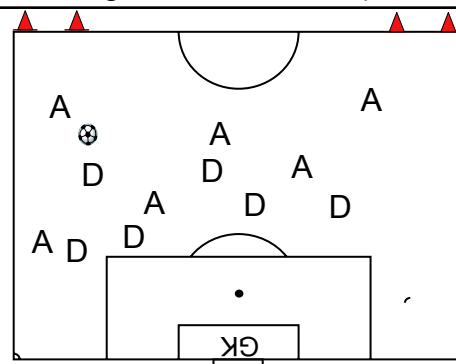

Attackers (A) play on goal.

Defenders counter through small goals.

10 min. games - rotate players.

Players should be busy at all times. If drills keep players inactive, break team into smaller groups and run parallel drills



# COMPETITIVE SOCCER PRACTICE # 2

Practice Focus: Flank Attack, Scoring

Time: 2 hrs

## Warm-Up: Dribbling, 1v1 (30 min)

1. Set up 10-15 (2 m) wide goals. Each player dribbles through each goal, accelerating out of goal and changing direction.
2. Runner's stretch (hold 20 sec. each side, 3 reps/side)
3. Dribble through a pair cones making the figure "8" as shown.



4. Quad stretch (hold 20 sec. each side, 3 reps/side).
5. A v B in a 15 m x 15 m grid with 4 small goals. Two pairs wait outside grid. A defends adjacent goals G1 and B defends goals G2. Play for 60 sec and rotate new pairs into grid. Each pair plays twice.
6. Hamstring stretch (hold 20 sec. each side, 3 reps/side).
7. Same set up as in step # 5. Two pairs are in grid now and play two separate 1v1 games. After 60 sec rotate one of the waiting pairs into grid.
8. Heel stretch (hold 20 sec. each side, 3 reps/side).

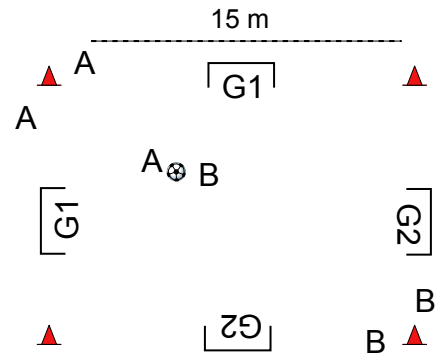
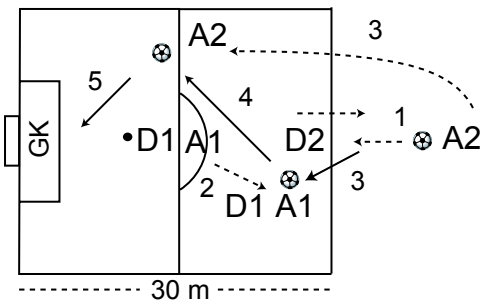

diagram for steps 5 & 7

## Technical Skill: 2v2 Give & Go with Shot on Goal (20 min.)



1. A2 dribbles towards D2 who is coming towards A1 to challenge.
2. A1 is making a diagonal run behind D2. D1 follows A1.
3. A2 passes to A1 and A2 immediately makes a wide run into space.
4. A1 rotates and makes a one touch pass into the run of A2.
5. A2 should be clear in the penalty box for a shot on goal.

## Fitness Drill: 6 v 3 (15 min.)

X's (6) play two touch soccer and attack large goal.

O's (3) defend large goal and after winning possession, counter attack through one of the two small (2 m wide) goals.

Play 3 games of 4 minutes rotating everyone through defense.

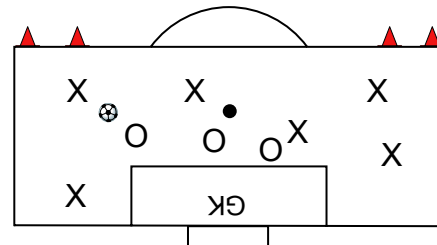

## Tactical Drill: 7 v 7 into four corners (25 min.)

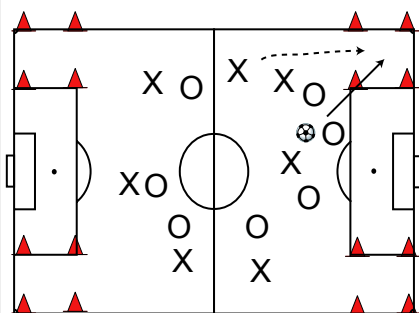

Team in possession scores point by passing to a player who has run into one of the four grids.

After a point, the other team gets the ball and must first play across half before scoring.

## Scrimmage: Flank Attack (30 min.)

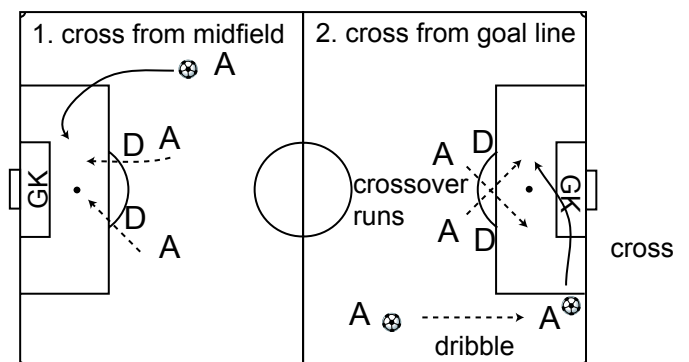

Players should be busy at all times. If drills keep players inactive, break team into smaller groups and run parallel drills



# COMPETITIVE SOCCER PRACTICE # 3

Practice Focus: Defending

Time: 2 hrs

## Warm-Up: Dribbling, Agility (30 min)

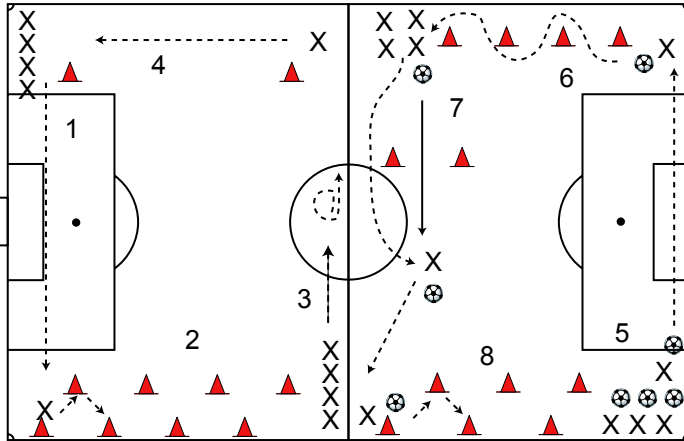

Split team into four groups and position at stations 1,3,5,7. Have each group go through circuit in their half once, then stretch (runners). Switch groups to other half of field and do a circuit, stretch (quads). Have groups do circuit in same half in reverse direction and stretch (hamstring). Switch groups back to their original half of field and do circuit in opposite direction of their first circuit, heel stretch. The following are the warm-up exercises at each station:

1. easy jog
  2. sideways run, cone to cone.
  3. jog with three complete turns, switching direction of turn.
  4. jog with header jumps every 5 m.
  5. dribble ball.
  6. dribble through cones.
  7. pass to yourself through cones, receive ball while it is still moving.
  8. dribble zig zag keeping the ball inside the cones.
- Vary distances between cones to suit skill of your team.

## Technical Skill: 1v1 with Shot on Goal (20 min.)

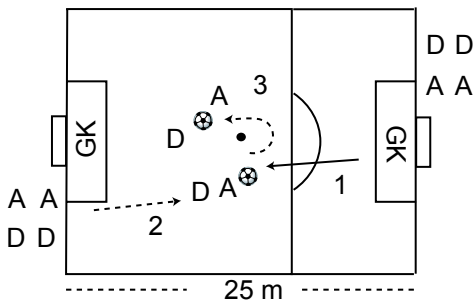

1. GK rolls or throws ball towards attacker (A) waiting at opposite goal.
2. A sprints to ball followed by defender (D)
3. Attacker receives ball and with first touch plays ball away from defender allowing attacker to turn and play 1v1 against defender. Attacker must finish with shot on goal.

After the 1v1 is completed, GK starts play on opposite goal.

## Fitness Drill: Agility/Sprint (15 min.)

1. Hop with both legs up.
2. Sidestep shuttle run.
3. Explosive forward sprint
4. Jog back to end of line.

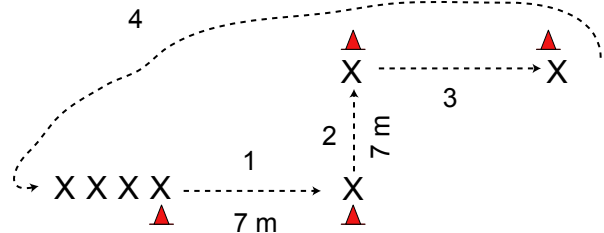

## Tactical Drill: 4+2 v. 2+4 (25 min.)

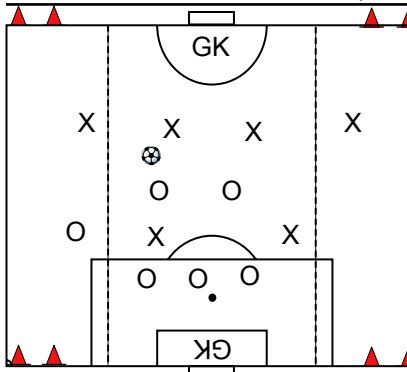

Field is divided into three zones.  
X play freely v. O.  
Goal scored into regular nets = 1 pt  
Goals scored into wide goals while at least one defender is trapped in opposite zone = 2pts.

## Scrimmage: 1v1 Defending in 7v7 (30 min.)

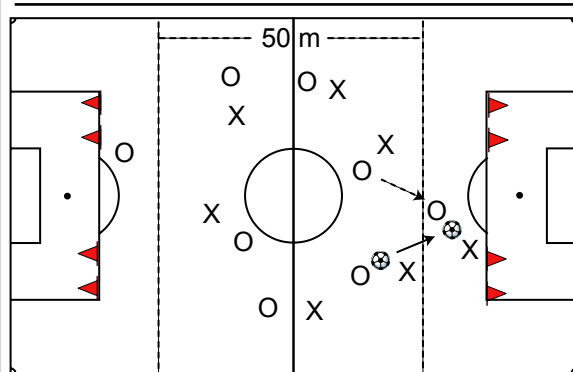

6v6 in a 50m wide zone.  
One player from each team is in defending zone.  
Attackers pass ball into end zone and play 1v1 on either of two small goals.  
After attempt is complete, def. plays ball back to middle.

Players should be busy at all times. If drills keep players inactive, break team into smaller groups and run parallel drills



# COMPETITIVE SOCCER PRACTICE # 4

Practice Focus: Passing, Anticipation, Transition

Time: 2 hrs

## Warm-Up: Anticipation, Passing (30 min)

- Groups of 5-7 players in a 20m x 20m grid. Players pass to each other and follow the pass. Players must call their name to receive the ball.
- Runner's stretch (3 x 30 sec each leg).
- Same groups, players are each given a number (1-7). Players must pass to each other in numerical sequence.
- Quad stretch (3 x 30sec. each).
- Give and Go in a 15m x 15m grid.

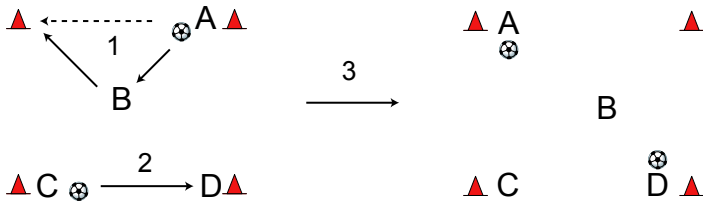

- A plays give and go with B to open cone.
- C passes ball to D at the same time.
- This is what the positions are after these passes. D now plays give & go with B, A passes to C.

Rotate everyone through position B every 3 min.

- Hamstring stretch (3 x 30 sec. each).
- In pairs, players one-touch pass to each other across the field and back.
- Heel stretch (3 x 30 sec. each).

## Technical Skill: Transition Play (20 min.)

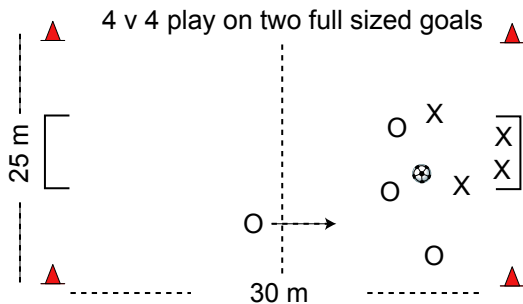

Two defenders (X) must be on goal line between posts before their two team mates can challenge attackers (O).

Attackers (O) must have all players in attacking half before they are allowed to score a goal.

After change of possession, O defends and two O's must sprint to goal line before the other two can challenge X's, who now attack and must have everyone across half before they can score a goal.

## Fitness Drill: Receive - Pass - Turn (10 min.)

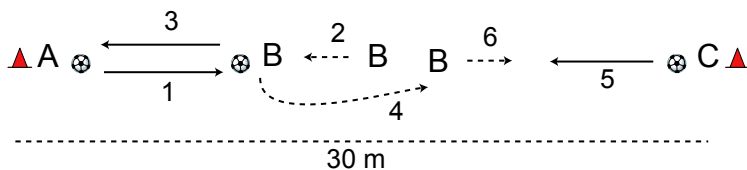

- A passes ball towards B.
- B attacks ball.
- B plays one touch pass back to A.
- After pass, B turns to face C.
- C passes ball towards B.
- B attacks ball.

Rotate each player for 3 minutes through position B

## Tactical Drill: 6v4 Pressing & Counterattack (25)

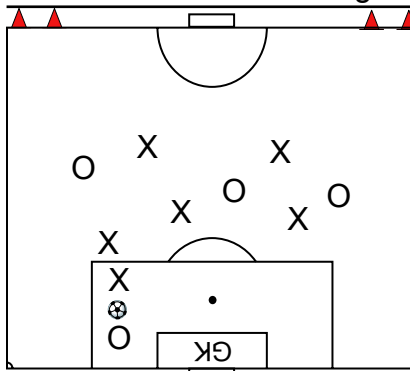

X's attack and O's defend regular goal. After O's win ball they counter 2 goals at half. Closest attacker X challenges O with ball and other X's support and close down passing lanes.

## Scrimmage: 7v7 with GK Transition Play (30 min.)

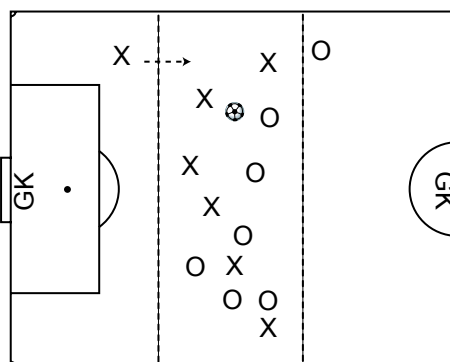

Divide half the field into 3 equal zones. Team in possession must have all players at least in middle before they can score. In own defending third only, teams play two touch soccer until ball is played out of defending zone.

Players should be busy at all times. If drills keep players inactive, break team into smaller groups and run parallel drills



# COMPETITIVE SOCCER PRACTICE # 5

Practice Focus: 1v1, Scoring, Transition Play

Time: 2 hrs

## Warm-Up: Dribbling & Shooting (30 min)

1. Dribble ball with changes of direction. Stop ball alternating between sitting on it and putting a knee on it.
2. Runner's stretch (3 x 30 sec each leg).
3. Set up as many cones as possible in one half of the field. Players dribble towards a cone and body fake left, then dribble by cone on the right. Alternate direction of fakes and dribbles past cone.
4. Quad stretch (3 x 30sec. each).
5. In pairs, players are 10m apart starting 40 m away from goal. Players pass diagonally to each other (give & go) and take a shot from the top of the penalty area.
6. Hamstring stretch (3 x 30 sec. each).
7. Shooting drill (see diagram on right)
  - a. X2 passes to X1
  - b. X1 touches ball to one side, turns and shoots.
  - c. X2 takes spot of X1.
8. Heel stretch (3 x 30 sec. each).

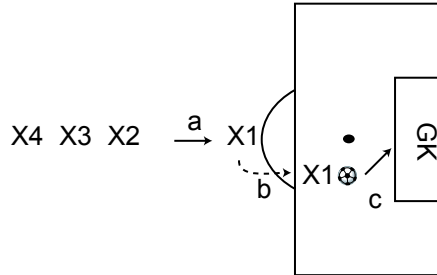

## Technical Skill: 1v1 (15 min.)

X's attack goal A and O's attack goal B.

- X2/O2 and X1/O1 stay in their own half.
- X2 passes ball to X1 who now plays 1v1 against O1 on goal A.
- If O1 wins ball, O1 passes to O2 who plays 1v1 against X2.

If goal is scored, ball goes out of play, GK restarts play by throwing ball in opposite half to attacking players.

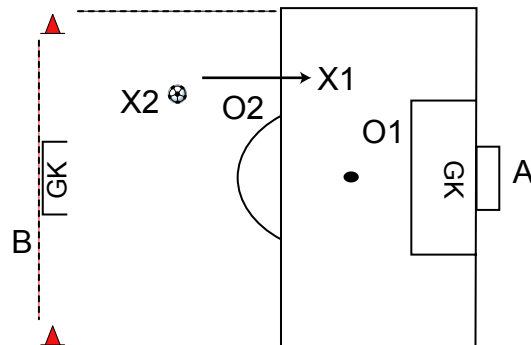

## Fitness Drill: Reaction Sprint and 1v1(15 min.)

1. X and O face goal and jog backwards away from goal.
2. When X changes direction and sprints to ball, O reacts and tries to beat X to the ball.
3. X and O play 1v1 on goal.
4. After 1v1 is finished, X goes to end of line O, and O to line X.

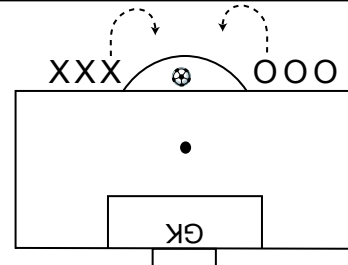

## Tactical Drill: Transition Play (30 min)

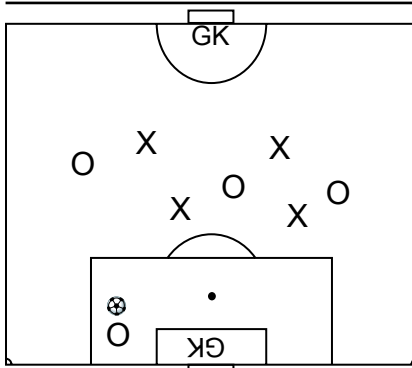

Play 4 v 4.  
5 minute games.

Both teams can score on either goal.

Teams cannot score on same goal twice in a row.

Set up 2 fields.

## Scrimmage: Transition Play (30 min.)

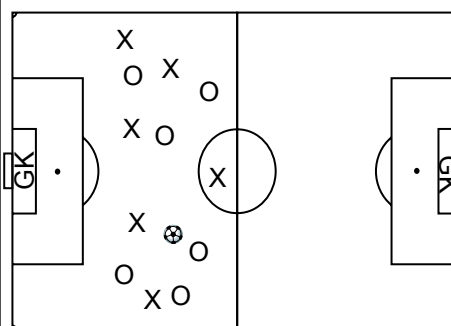

Teams play 6v6 in one half of the field, keeping possession of the ball. On command by coach, team in possession breaks across half and tries to score. Other team tries to win ball and score on same goal. 2 pts for goal by breaking team, 1 pt for goal by other team.

Players should be busy at all times. If drills keep players inactive, break team into smaller groups and run parallel drills



# COMPETITIVE SOCCER PRACTICE # 6

Practice Focus: Ball Control, Flank Attack

Time: 2 hrs

## Warm-Up: Dribbling & Crossing (30 min)

1. Dribble ball with outside of foot. Stop with ball of foot and then take it away at right angle with outside of same foot. Keep dribbling randomly on field, alternating feet.
2. Runner's stretch (3 x 30 sec each leg).
3. Dribble and execute scissors move at highest pace possible. Move has to be a sharp change of direction.
4. Quad stretch (3 x 30sec. each).
5. Groups of 3 players pass ball to each other down one side of the field. One of the three makes a call for a final pass to the corner, while the others break into penalty box. Player in corner crosses ball into box for other two players to finish.
6. Hamstring stretch (3 x 30 sec. each).
7. Half the players each have a ball in their hand and are spread out inside the penalty box. Players without ball sprint to any player with ball and call for the ball. Players throw ball for header or one touch pass back.
8. Heel stretch (3 x 30 sec. each).

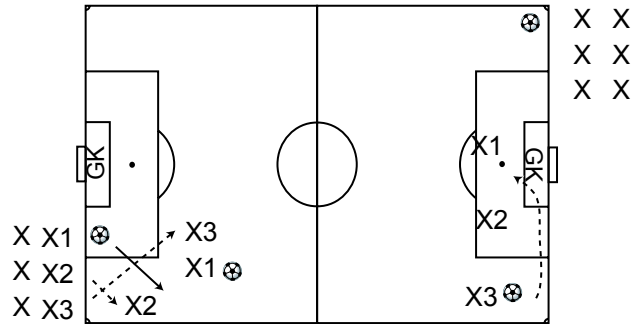

## Technical Skill: 4v4 Flank Attack (30 min.)

Set up field twice the size of penalty box.

Play 4 v 4 with 4 neutral players (N) positioned along sidelines.

Team in possession can use neutral players who must play a cross or pass back to the team that played the ball out to them.

Rotate teams through neutral positions every 5 minutes.

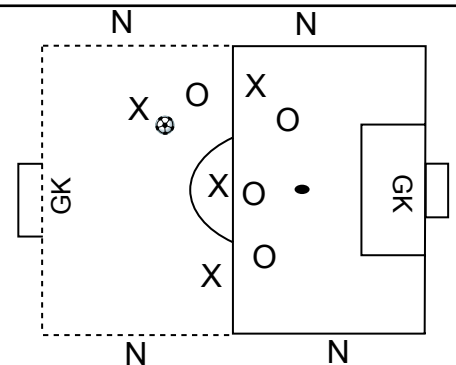

## Fitness Drill: 3v1 with Crossing (15 min.)

1. 3 groups play 3v1 inside 10m x 10m grid.
2. Groups 1 and 2 alternate sending a player to the corner with a pass.
3. Player crosses to group 4 who play 3v1 on goal.
4. Rotate groups every 3 minutes

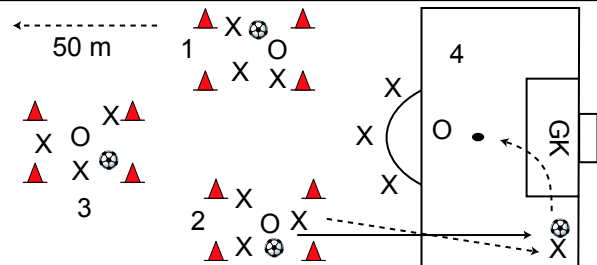

## Tactical Drill: 6v6 Flank Attack (20 min)

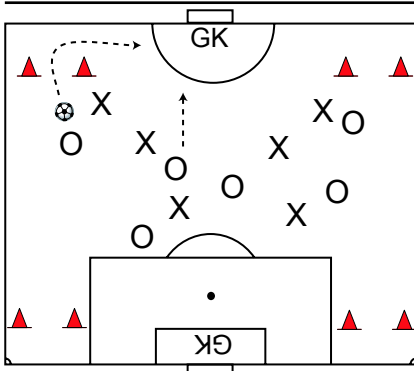

Teams must pass to team mate or dribble through one of the wide goals before they can cross on goal.

## Scrimmage: 4v4 & 3v2 (25 min.)

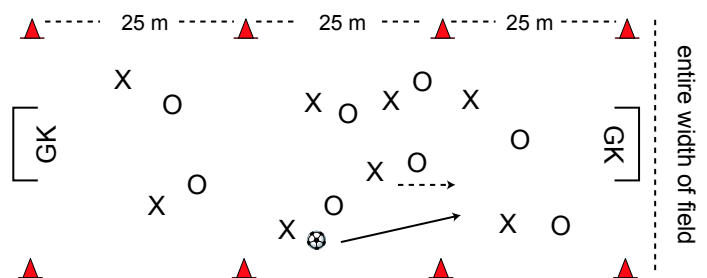

4v4 in middle sections: team in possession tries to send a player into either end zone to set up a 3v2 on goal.

Players should be busy at all times. If drills keep players inactive, break team into smaller groups and run parallel drills





# COMPETITIVE SOCCER PRACTICE # 7

Practice Focus: Scoring Goals, Flank Attack

Time: 2 hrs

## Warm-Up: Passing (25 min)

1. In pairs, players pass across field and back (give & go) using two touches maximum.
2. Runner's stretch (3 x 30 sec each leg).
3. Players are in pairs and face each other. Starting point is half way across the field, players 2m apart. Players one-touch pass to each other while moving backwards to increase distance between them to 25 m. They then decrease the distance back to 2m while passing, ending up where they started.
4. Quad stretch (3 x 30sec. each).
5. In pairs, players face each other about 10m apart. Starting position is at the corner flag. They pass the ball to each other diagonally while shuttling (side stepping) to center field and back.
6. Hamstring stretch (3 x 30 sec. each).
7. In pairs, players pass ball diagonally forward to each other with one touch while moving around half the field.
8. Heel stretch (3 x 30 sec. each).

It is important to ask players for 100% accuracy of passes at the fastest speed possible.

step # 5

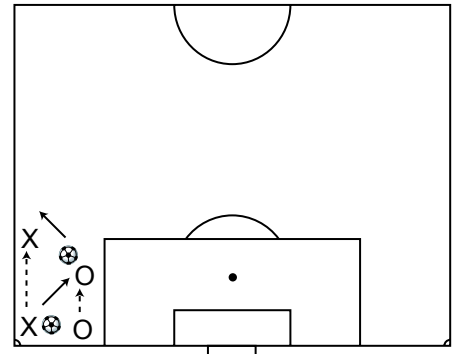

## Technical Skill: 4v4 in Small Area (35 min.)

Set up field twice the size of penalty box.

X is the attacking team, O is the defending team.

X's can score into either goal, but must play ball across the half line first after an attempt on goal.

Play 5 minute games switching roles of teams (attackers/defenders).

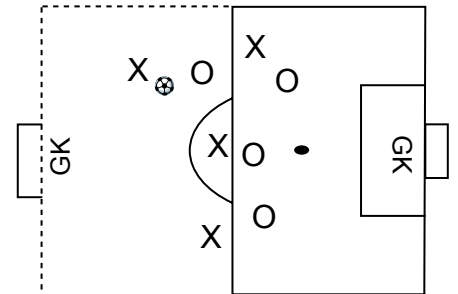

## Fitness Drill: Sprint and Score (15 min.)

1. Server (S) throws ball straight across top of 6 yd box towards near post.
2. X and O sprint from top of penalty box, X to near post and O to far post. If X misses, O must finish with header/shot on goal.
3. Server varies ball on ground for kick, a sliding kick, header, or diving header.

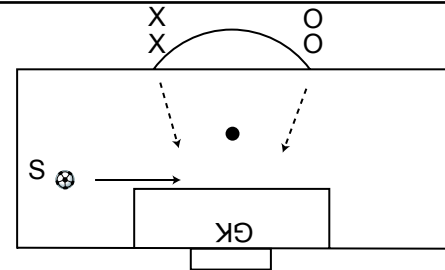

## Tactical Drill: 4v4 + N Crossing (20 min)

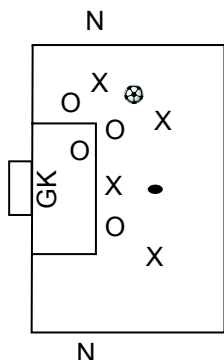

X and O play 4v4 game inside the penalty box.

Team in possession must play to either neutral player who must cross the ball to the team that played the ball out. If defending team wins ball, they now attack and play it out to neutral player.

## Scrimmage: 7v7 Flank Attack (25 min.)

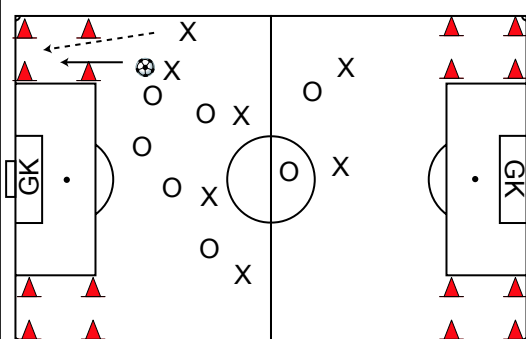

Both teams can score on either goal after passing ball to a team mate in one of the corner squares. Players cannot be challenged in square. Teams must play ball across center before they can score again.

Players should be busy at all times. If drills keep players inactive, break team into smaller groups and run parallel drills



# COMPETITIVE SOCCER PRACTICE # 8

Practice Focus: Crossing Balls, Scoring

Time: 2 hrs

## Warm-Up: Agility, Ball Control, Fun (30 min)

All drills take place in the penalty box.

1. Half of the players are spread around in the penalty box, standing with legs apart. The other players each have a ball and dribble towards a stationary player. They now pass the ball through the legs of the standing player, run around the standing player and collect their own pass. After everyone has passed through all players, switch roles.
2. Runner's stretch (3 x 30 sec each leg).
3. Same sequence as step (1), except players without ball lie on their back. Players with ball chip over players on the ground and jump over them to collect their ball.
4. Quad stretch (3 x 30sec. each).
5. Same sequence again, players without ball form an arch leaning forward with hands on the ground. Players with ball pass through the arch and run around the arching player to collect their ball.
6. Hamstring stretch (3 x 30 sec. each).
7. Same drill again. Player without ball are with hands and knees on ground forming a tight "box" with head tucked in. Players with ball chip over "box" and jump over "box" to collect ball.
8. Heel stretch (3 x 30 sec. each).

## Technical Skill: Two Touch Shooting (15 min.)

1. Players on goal line play a firm pass to players at the top of the box.
2. Players receive the pass and with their first touch set up a second touch shot. The first touch should be diagonally ahead.
3. The shot should be aimed at the far post.

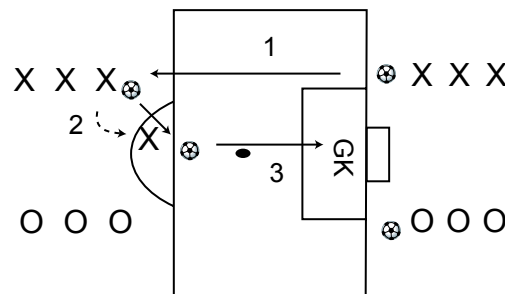

Players who pass follow their pass and go to line at the top of box, shooters go to end of "passers" line.

## Fitness Drill: Dribble and Cross (15 min.)

1. Wide players dribble past cone close to goal line.
2. Once past cone, they cross ball to target areas at the top of the 6 yd box, in line with goal posts.
3. Attackers (A) time their runs to the cross and finish on goal. Alternate sides of crosses. Players (X) who crossed go to attacking line, players (A) that tried to score go to crossing line.

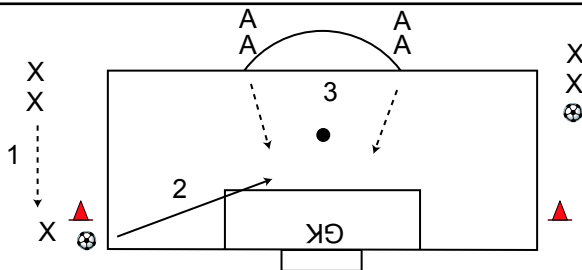

## Tactical Drill: Crossing (30 min)

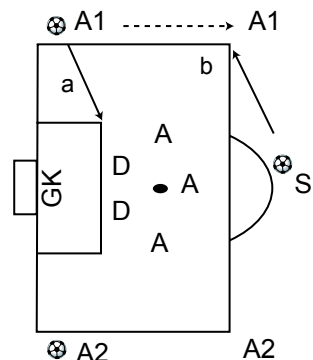

- a. A1 and A2 take turns crossing the ball into the penalty box. In the box, three attackers try to score against two defenders.
- b. If defenders win the ball, they play it to S outside the box. A1 and A2 now must sprint to top of box to receive a pass from S. They now dribble to goal line for a new cross.

## Scrimmage: 7v7 with Crossing (30 min.)

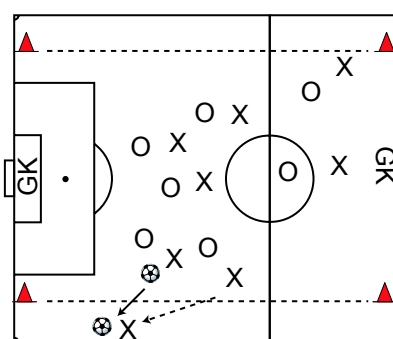

- Two teams play 7v7 two-touch soccer on 3/4 field.
- Cones along each side mark a free "crossing" lane.
- Team in possession can pass the ball to a player running into crossing lane, where they cannot be challenged.
- Teams get 2pts for a goal after a cross and 1 pt for a goal through middle.

Players should be busy at all times. If drills keep players inactive, break team into smaller groups and run parallel drills



# COMPETITIVE SOCCER PRACTICE # 9

Practice Focus: Defending

Time: 2 hrs

## Warm-Up: Circuit (30 min)

1. All players dribble freely inside a large square.
2. One at a time, players leave square and dribble around outside of staggered cones.
3. The lines are hurdles or any other obstacles players can jump over. After cones, players pass to a server and sprint over hurdles. Server passes ball back into run of player.
4. Player collects ball and passes through a 3m wide goal. They run around goal and collect their own pass.
5. Player now speed dribbles on outside of cones down 3/4 field.
6. Player cuts inside, dribbles past the last cone and takes a shot on goal.

Players do runner's stretch before they leave grid, then do three circuits with quad, hamstring, heel stretch after each circuit.

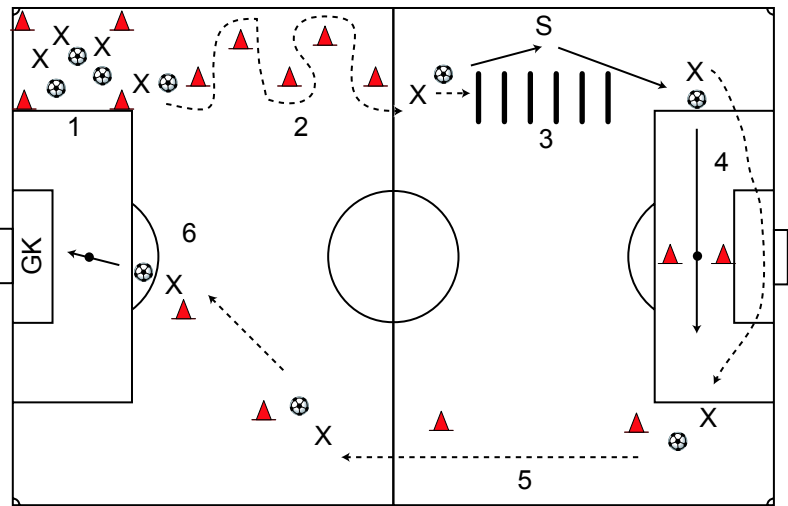

## Technical Skill: 1v2 Defending (20 min.)

Attackers (A) and defenders (D) each defend a small goal.

A1 plays 1v2 against two defenders. A2 waits next to goal A's are defending.

A1 can attack defenders or pass back to A2. If A1 passes back, then A2 moves up and plays against D's while A1 takes spot A2 vacated.

If a defender wins the ball, that D now plays 1v2 against both A's while the second defender drops back next to goal D's are defending.

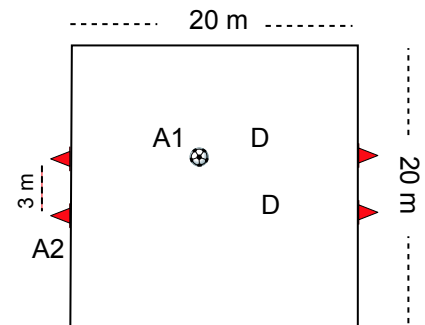

## Fitness Drill: Sprint and 1v1(20 min.)

A sprints towards ball. That is the signal for D to react and also sprint to the ball.

The first player to touch the ball is the attacker and plays 1v1 against the other player who defends.

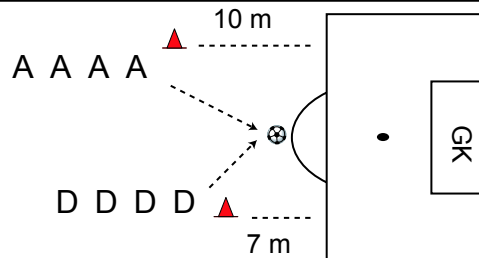

## Tactical Drill: 4v3 + GK (20 min)



## Scrimmage: 8v8 (30 min.)

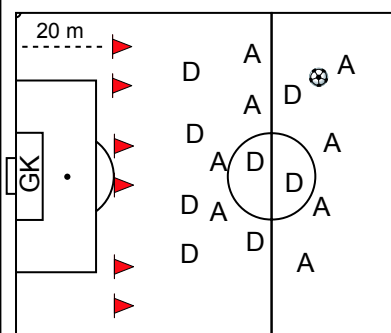

Attackers (A) must dribble through one of small (3m) goals before they can score.

The player who dribbled through cannot be challenged and gets a free shot on goal.

If defenders win the ball, they play it out to A1 who restarts the attack.

Players should be busy at all times. If drills keep players inactive, break team into smaller groups and run parallel drills



# COMPETITIVE SOCCER PRACTICE # 10

Practice Focus: Flank Attack # 2

Time: 2 hrs

## Warm-Up: Circuit with Passing & Control (30 min)

Players work in pairs.

1. Players one-touch pass to each other down the side line.
2. Partners are 7m apart and facing each other. They one-touch pass to each other across the field. One player runs backwards, the other forwards.
3. Players two-touch pass to each other down the side line.
4. Players are 7m apart facing each other. The player running forward throws the ball to the player running backwards who heads it back.

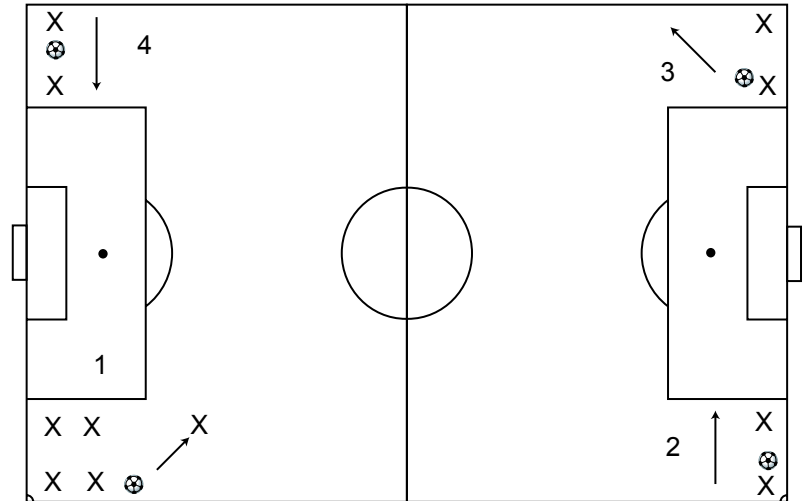

Circuit - runner's stretch - circuit - quad stretch - circuit - hamstring stretch - circuit - heel stretch.

## Technical Skill: Crossing and 2v1 (15 min.)

1. X dribbles along outside of penalty box, past cone,
2. X crosses ball towards top of box.
3. Attackers (A) win ball and play 1v1 against defender (D), who waits besides the goal until the cross is played in.

Rotate players such that everyone crosses, attacks and defends.

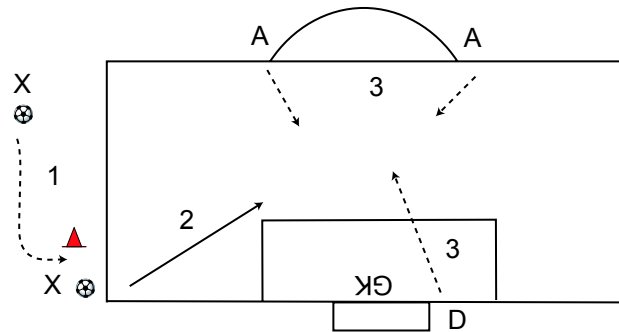

## Fitness Drill: 4v4 in Penalty Box with Crosses (20 min.)

4v4 in penalty box on two full size goals with goalkeepers.

Teams can use players on side lines for crosses. Players outside box cannot challenge each other.

Players on side line can rotate into box to change place with a team mate.

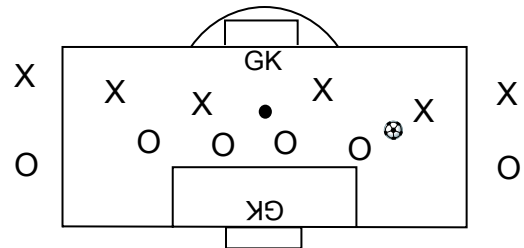

## Tactical Drill: 4v4 with 3 Groups (25 min)

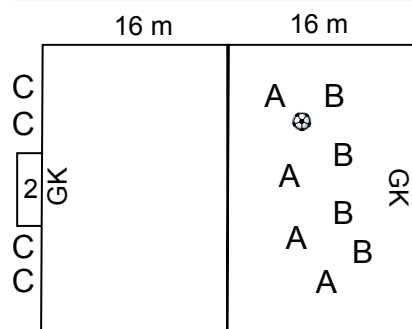

A's attack goal 1 defended by team B. If A scores or B gets possession, B now breaks to attack goal 2. Team C comes out to defend goal 2 once B crosses the center line. A drops to goal line of goal 1 and waits for C to attack.

## Scrimmage: 5v4 (30 min.)

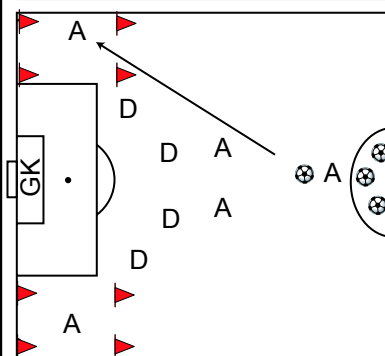

(A) near center circle plays a long ball to A in one of the wide zones.

Once A receives the ball, defenders (D) can challenge. If D's win ball, they clear it past half. A's reset and start a new attack.

Players should be busy at all times. If drills keep players inactive, break team into smaller groups and run parallel drills

# Youth Competitive

## Warm-Up Drills



## Warm - Up # 1: Passing, Headers, 1v1

1. Set up 10-15 (2 m) wide goals. In partners, freely move around passing ball through all goals.
2. Runner's stretch (hold 20 sec. each side, 3 reps/side)
3. Groups of three players form triangles standing 5 m apart from each other.  
Player 1 throws to player player 2, who heads to player 3.  
Player 3 throws to P1 who heads to P2, etc.
4. Quad stretch (hold 20 sec. each side, 3 reps/side).
5. 4 pairs play 1v1 in a 25m x 25m grid with two full size goals and goalkeepers.  
Two neutral players in the grid can be used by any other pair.  
Shots on goal must follow a give & go with one of the neutral players.
6. Hamstring stretch (hold 20 sec. each side, 3 reps/side).
7. Same set up as in step # 5.  
Four players are on diagonally opposite sides of the goals.  
- X's start with a ball each. First player X starts to attack opposite goal. O challenges X and both now play 1v1 on the same goal.  
- after all X's have started, O's start with ball and attack goal.
8. Heel stretch (hold 20 sec. each side, 3 reps/side).

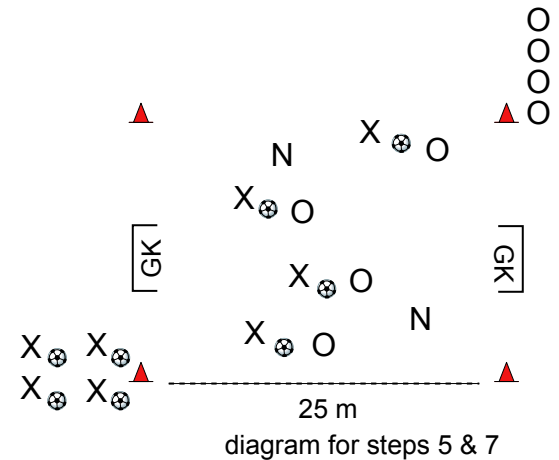

### Coaching Points/Progression

- Step 1: Challenge players to lead partners through goal with a pass. The more skilled your team, the smaller the area should be. Players need to stay aware of other's to avoid collisions.
- Step 3: As players get the routine of the drill, challenge them to throw the ball higher for jumping headers. Emphasize technique of arching backwards and hitting ball square for power.
- Step 5: Neutral players could be your playmakers/midfielders. They need to vocally ask for the ball so they "can make the play" and set up the shot on goal.  
Instead of having two more groups waiting, you can set up a second grid. Use cones to make the goals and rotate players through the goalie position.
- Step 7: Players starting need to enter the field with a fast "power dribble". Again, set up more than one grid. Consider playing 2v2 or 3v3.

### Coach's Notes



## Warm - Up # 2: Dribbling, 1v1

1. Set up 10-15 (2 m) wide goals. Each player dribbles through each goal, accelerating out of goal and changing direction.
2. Runner's stretch (hold 20 sec. each side, 3 reps/side)
3. Dribble through a pair cones making the figure "8" as shown.



4. Quad stretch (hold 20 sec. each side, 3 reps/side).
5. A v B in a 15 m x 15 m grid with 4 small goals.  
Two pairs wait outside grid.  
A defends adjacent goals G1 and B defends goals G2.  
Play for 60 sec and rotate new pairs into grid. Each pair plays twice.
6. Hamstring stretch (hold 20 sec. each side, 3 reps/side).
7. Same set up as in step # 5.  
Two pairs are in grid now and play two separate 1v1 games.  
After 60 sec rotate one of the waiting pairs into grid.
8. Heel stretch (hold 20 sec. each side, 3 reps/side).

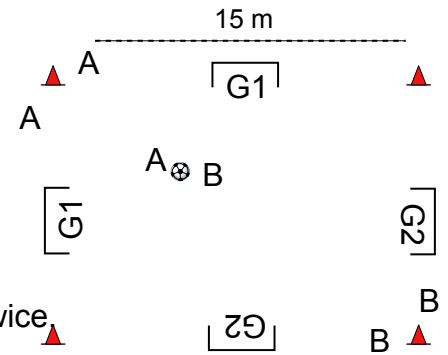

diagram for steps 5 & 7

### Coaching Points/Progression

- Step 1: Make area smaller for more advanced teams. Players need to keep head up to perceive
- movement around them and avoid collisions.
- Step 3: Set up a pair of cones for each player and challenge them to tight turns around the cones
- at as high a pace as possible. Once successful, ask players to move between sets of
  - requiring awareness and perception to see which set is available - avoid waiting at cones.
- Step 5: Players need to attack one goal and then fake the defender and quickly change direction
- to attack the adjacent goal. The more frequent, quick, and innovative the change of
  - direction the more the defender is challenged and the more goals will be scored.
  - Defenders on the other hand need to position their bodies (stance) to protect the goal
  - that is being attacked while being ready to rotate to defend the 2nd goal. Adjust the size
  - of the goals to increase difficulty of scoring. Goalkeepers need to play near post angle.
- Step 7: This increases traffic so players need to "see" the field. More challenging for goalkeepers.

### Coach's Notes



## Warm - Up # 3: Dribbling, Agility

Split team into four groups and position at stations 1,3,5,7. Have each group go through circuit in their half once, then stretch (runners).

Switch groups to other half of field and do a circuit, stretch (quads). Have groups do circuit in same half in reverse direction and stretch (hamstring). Switch groups back to their original half of field and do circuit in opposite direction of their first circuit, heel stretch.

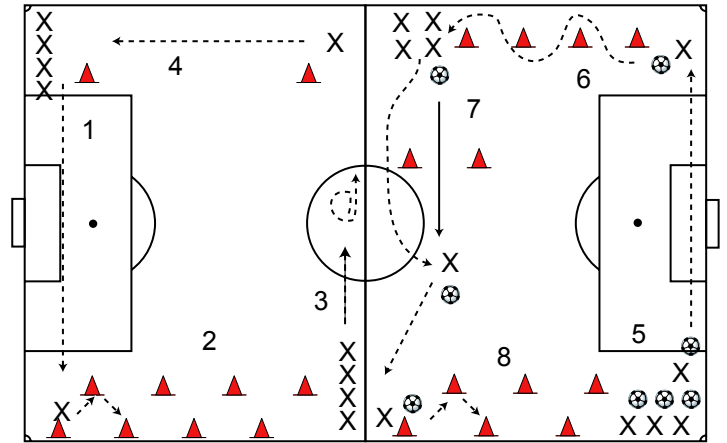

The following are the warm-up exercises at each station:

1. easy jog
  2. sideway run, cone to cone.
  3. jog with three complete turns, switching direction of turn.
  4. jog with header jumps every 5 m.
  5. dribble ball.
  6. dribble through cones.
  7. pass to yourself through cones, receive ball while it is still moving.
  8. dribble zig zag keeping the ball inside the cones.
- Vary distances between cones to suit skill of your team.

### Coaching Points/Progression

Step 1: Allow players to vary movement during jog, like knee raises, hip rotations, etc.

Step 2: Players stay inside cones and must run sideways (shuttle).

Step 3: Turns must be while running forward, no stopping.

Step 4: Ask for increasing height of jumps with each round.

Step 5: Keep ball close to feet while dribbling at fastest pace possible.

Step 6: Challenge players to switch ball from inside to outside foot while dribbling and making turns.

Step 7: The players must receive the ball while ball is still in motion.

Step 8: Again, dribble with inside foot and then execute change of direction by using outside foot.

### Coach's Notes





## Warm - Up # 4: Anticipation, Passing

1. Groups of 5-7 players in a 20m x 20m grid. Players pass to each other and follow the pass. Players must call their name to receive the ball.
2. Runner's stretch (3 x 30 sec each leg).
3. Same groups, players are each given a number (1-7). Players must pass to each other in numerical sequence.
4. Quad stretch (3 x 30sec. each).
5. Give and Go in a 15m x 15m grid.

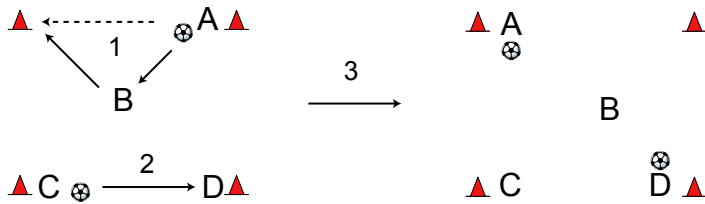

1. A plays give and go with B to open cone.
2. C passes ball to D at the same time.
3. This is what the positions are after these passes.

D now plays give & go with B, A passes to C.

Rotate everyone through position B every 3 min.

6. Hamstring stretch (3 x 30 sec. each).
7. In pairs, players one-touch pass to each other across the field and back.
8. Heel stretch (3 x 30 sec. each).

### Coaching Points/Progression

1. Emphasize one-touch passing and quick movement. Observe patten of play and make sure players don't end up in a circle. Ask for diagonal passes/runs.
3. Players must now rember the numbers of others. This may take a while so encourage them to communicate and help each other. At the same time, they need to vary runs as in (1). This drill is a challenge for concentration while playing effective soccer.
5. The objective of this drill is to achieve "fluidity". Timing of passes need to be synchronized such that the balls are always moving. This may take some time and you may need to stop the drill and demand attention to the timing of passes and runs.
7. Demand perfection. Passes need to be timed so that both players maintain a straight line in their running direction, i.e. the diagonal pass shouldn't cause a player to chase or to have to cut inside to receive it.

### Coach's Notes



## Warm - Up # 5: Dribbling & Shooting

1. Dribble ball with changes of direction. Stop ball alternating between sitting on it and putting a knee on it.
2. Runner's stretch (3 x 30 sec each leg).
3. Set up as many cones as possible in one half of the field. Players dribble towards a cone and body fake left, then dribble by cone on the right. Alternate direction of fakes and dribbles past cone.
4. Quad stretch (3 x 30sec. each).
5. In pairs, players are 10m apart starting 40 m away from goal. Players pass diagonally to each other (give & go) and take a shot from the top of the penalty area.
6. Hamstring stretch (3 x 30 sec. each).
7. Shooting drill (see diagram on right)
  - a. X2 passes to X1
  - b. X1 touches ball to one side, turns and shoots.
  - c. X2 takes spot of X1.
8. Heel stretch (3 x 30 sec. each).

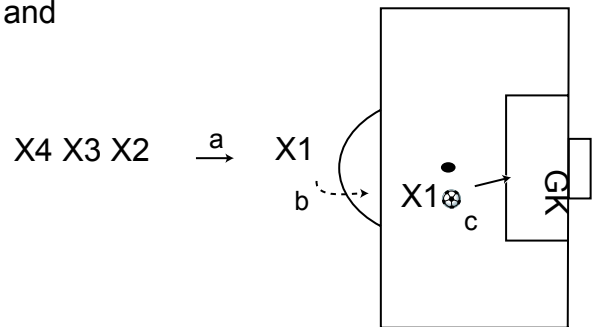

### Coaching Points/Progression

1. Sitting and kneeling motion must be fast - players need to judge speed of ball before stopping it.
3. Players need to slow down just before the cone to execute a sharp, quick, and controlled change of direction. After change of direction they must dribble into new direction starting with an explosive burst of speed. This is how defenders are "left standing". Players dribble to different cones looking up to make sure that only one player attacks each cone. If you start with more cones than players and players are successful, then reduce the number of cones.
5. The last pass before the shot must be timed and paced such that the shooter can strike with one touch - no need to control the ball first.
7. Stress accuracy of first pass and first touch by shooter so that the shot on goal is set up perfectly on the foot of the shooter for a strike towards the far post. Once execution is accurate and flows well, increase the pace of the first pass to the shooter. Remind shooters to look up prior to shot to pick the target (far post corner).

### Coach's Notes



## Warm - Up # 6: Dribbling & Crossing

1. Dribble ball with outside of foot. Stop with ball of foot and then take it away at right angle with outside of same foot.  
Keep dribbling randomly on field, alternating feet.
2. Runner's stretch (3 x 30 sec each leg).
3. Dribble and execute scissors move at highest pace possible.  
Move has to be a sharp change of direction.
4. Quad stretch (3 x 30sec. each).
5. Groups of 3 players pass ball to each other down one side of the field. One of the three makes a call for a final pass to the corner, while the others break into penalty box. Player in corner crosses ball into box for other two players to finish.
6. Hamstring stretch (3 x 30 sec. each).
7. Half the players each have a ball in their hand and are spread out inside the penalty box. Players without ball sprint to any player with ball and call for the ball.  
Players throw ball for header or one touch pass back.
8. Heel stretch (3 x 30 sec. each).

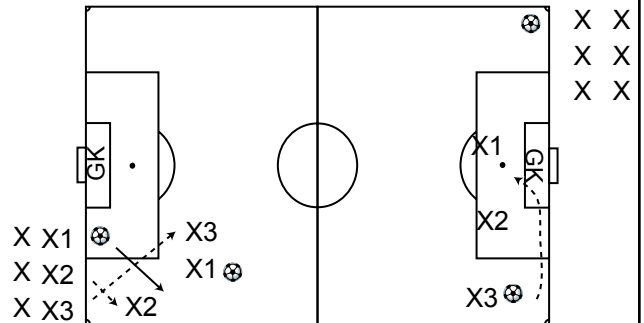

diagram for step 5

### Coaching Points/Progression

1. The more skilled and proficient your players are, the smaller the dribbling area should be.  
Players must keep head up to be aware of others and to avoid collisions. Ask for perfection of the move before you challenge players to a daster pace.
3. Same as in (1)
5. Formation of players while passing down the field should always be three across. This will force players to "read" each other's runs and communicate to avoid two going to the same spot. At the end two players need to sprint into penalty box to receive a well timed cross.
7. Communication and awareness are critical to ensure only one player approaches the player with the ball. When this drill is moveing well, then all players will be sprinting without having to wait for a spot to be open. Players with ball must stay focused so that they serve the ball properly to keep the approaching player's motion "fluid".

### Coach's Notes



## Warm - Up # 7: Passing

1. In pairs, players pass across field and back (give & go) using two touches maximum.
2. Runner's stretch (3 x 30 sec each leg).
3. Players are in pairs and face each other. Starting point is half way across the field, players 2m apart. Players one-touch pass to each other while moving backwards to increase distance between them to 25 m.  
They then decrease the distance back to 2m while passing, ending up where they started.
4. Quad stretch (3 x 30sec. each).
5. In pairs, players face each other about 10m apart.  
Starting position is at the corner flag. They pass the ball to each other diagonally while shuttling (side stepping) to center field and back.
6. Hamstring stretch (3 x 30 sec. each).
7. In pairs, players pass ball diagonally forward to each other with one touch while moving around half the field.
8. Heel stretch (3 x 30 sec. each).

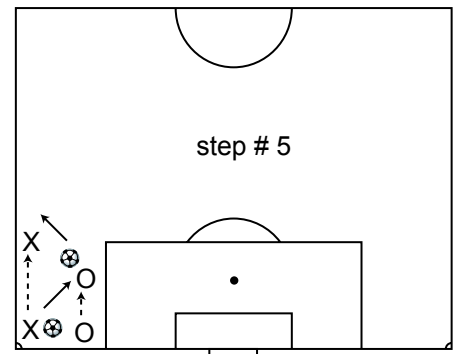

It is important to ask players for 100% accuracy of passes at the fastest speed possible.

### Coaching Points/Progression

1. The timing and direction of the pass must allow the receiver to reach the ball while maintaining direction of run. the first touch must be timed to the speed of the run. Pair up players the way they would play together in a game so they can get used to each other's speeds.
3. This drill is done across the width of the field between the side lines. The backwards runs are slow enough to allow 3-5 passes.
5. This may seem awkward at the beginning and you may need to stress that this is an agility and ball control exercise, not necessarily representing a game situation. Set up as many groups as you need across the field allowing enough space to avoid interference between groups.
7. It is important to time the runs and passes while turning the corners to keep moving without stopping or having to change speed of the run. The player who makes the pass while approaching the turn needs to judge the speed of their partner.

### Coach's Notes



## Warm - Up # 8: Agility, Ball Control, Fun

All drills take place in the penalty box.

1. Half of the players are spread around in the penalty box, standing with legs apart. The other players each have a ball and dribble towards a stationary player. They now pass the ball through the legs of the standing player, run around the standing player and collect their own pass. After everyone has passed through all players, switch roles.
2. Runner's stretch (3 x 30 sec each leg).
3. Same sequence as step (1), except players without ball lie on their back. Players with ball chip over players on the ground and jump over them to collect their ball.
4. Quad stretch (3 x 30sec. each).
5. Same sequence again, players without ball form an arch leaning forward with hands on the ground. Players with ball pass through the arch and run around the arching player to collect their ball.
6. Hamstring stretch (3 x 30 sec. each).
7. Same drill again. Player without ball are with hands and knees on ground forming a tight "box" with head tucked in. Players with ball chip over "box" and jump over "box" to collect ball.
8. Heel stretch (3 x 30 sec. each).

### Coaching Points/Progression

The ball should never touch the "obstacle" player. The fun part is players initially questioning each other's ability to avoid hitting the obstacles. Let it go for a few seconds, but then emphasize the importance of this drill. Passes need to be accurate and with the highest level of control. The "obstacle" players must not be hit by the ball. The chips over the players must be soft and with control so that the player chipping the ball can reach it within at most 2 m of the obstacle. If players are having trouble with the chips then practice chipping the ball without any obstacle. The soft chips in particular will be useful in a game when the player with the ball is "cornered" by defenders and needs to chip the ball over their feet to get away.

If the ground is wet or cold, do not ask players to lie on their backs in step (3).

### Coach's Notes



## Warm - Up # 9: Circuit

1. All players dribble freely inside a large square.
  2. One at a time, players leave square and dribble around outside of staggered cones.
  3. The lines are hurdles or any other obstacles players can jump over. After cones, players pass to a server and sprint over hurdles. Server passes ball back into run of player.
  4. Player collects ball and passes through a 3m wide goal. They run around goal and collect their own pass.
  5. Player now speed dribbles on outside of cones down 3/4 field.
  6. Player cuts inside, dribbles past the last cone and takes a shot on goal.
- Players do runner's stretch before they leave grid, then do three circuits with quad, hamstring, heel stretch after each circuit.

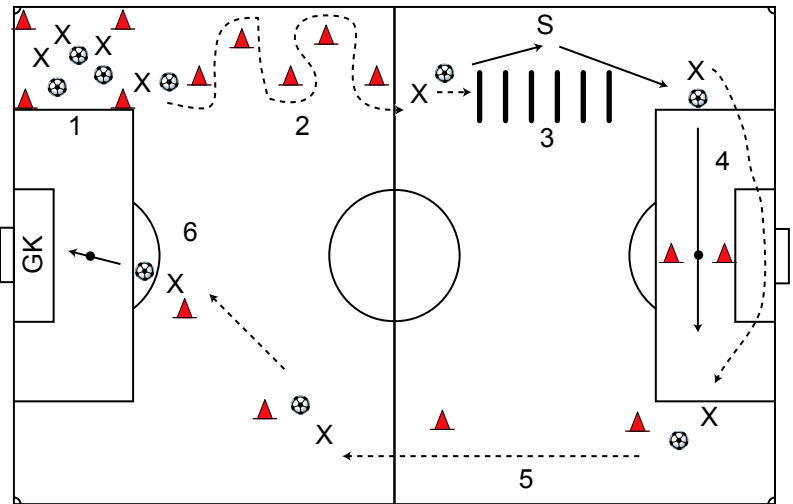

### Coaching Points/Progression

1. Release players from the grid as soon as the previous player dribbles past 3rd cone in step 2.
2. Use about 10-15 cones. Encourage players to switch between inside/outside foot as they change direction around cones. Emphasize accuracy (not hitting cones) over speed. If using tall cones, (not flat discs), have a volunteer available to pick up cones that get knocked down.
3. The server can be a coach or a player. The server must be capable to play an accurate and well timed pass to the runner such that the runner can collect the pass without braking stride.
4. Player and ball must arrive at their destination at the same time - weight pass accordingly.
5. Players must dribble as fast as possible while keeping close control of the ball. they should not be playing long passes to themselves.
6. The final touch past the cone must be timed to allow the next touch to be a shot. After the speed dribble this will force players to change speed and increase focus and concentration.

### Coach's Notes



## Warm - Up # 10: Circuit with Passing & Control

Players work in pairs.

1. Players one-touch pass to each other down the side line.
2. Partners are 7m apart and facing each other. They one-touch pass to each other across the field. One player runs backwards, the other forwards.
3. Players two-touch pass to each other down the side line.
4. Players are 7m apart facing each other. The player running forward throws the ball to the player running backwards who heads it back.

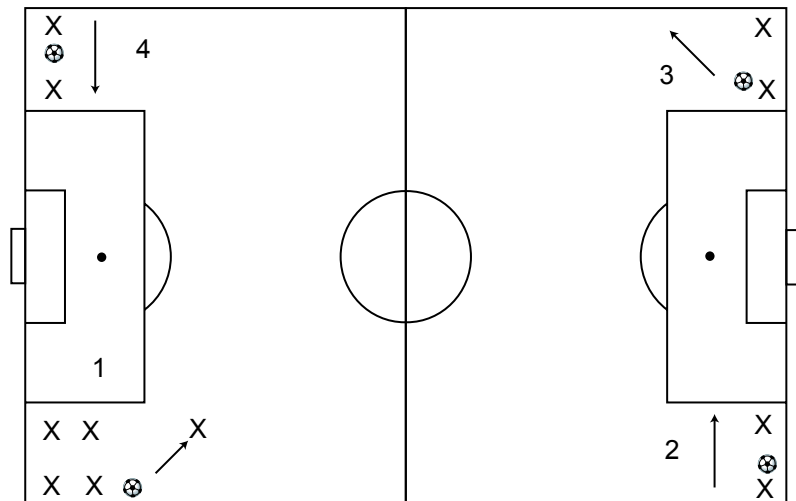

Circuit - runner's stretch - circuit - quad stretch - circuit - hamstring stretch - circuit - heel stretch.

### Coaching Points/Progression

1. Passes must lead the runners in a moderate pace (no sprinting to ball) and allow them to run in a straight line while receiving the ball.
2. Players must time their runs and passes to maintain the same distance between them.
3. Players must time passes, runs and especially first touches to keep constant speed and direction. Ask your players if they ever watched a game on TV and noticed two players in a give & go down the sideline where the ball is too far ahead or behind the receiver. This is the drill to get the timing right, as is drill (1). Ask players to increase speed without sacrificing accuracy.
4. Challenge the players to jump high for the header and keep moving backwards with the first "landing step". Maintain distance between players.

### Coach's Notes

# Youth Competitive

**Technical Skills**





## Technical Skill # 1: 3v2 with Shot on Goal

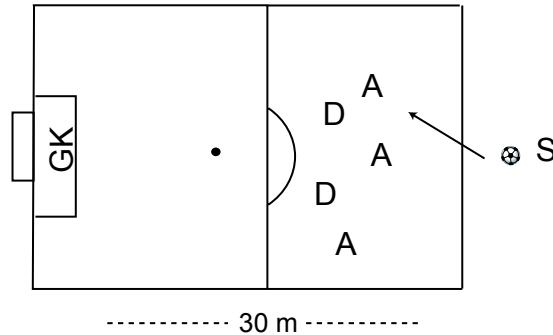

Server (S) plays ball to one of the attackers (A) outside the penalty area.

Attackers play 3v2 and try to combine to get a shot on goal and score.  
If defenders win the ball, they must play it back out to server.

Set up two groups or more depending on number of players.

Play 5 minute games and rotate defenders and attackers.

### Coaching Points/Progression

Attackers must move into spaces to get open to receive the pass from the server. Once the pass is played, attacker must attack (sprint to) ball to lose the defender. The first touch by the attacker should ideally be away from the pressuring defender to allow the attacker to turn and face the goal.

The pass from the server must come quickly - players shouldn't move for a long time to set up a pass - play it like in a game - little time for decisions and actions. Ask players to communicate. The 3v2 should be as much one-touch passing to set up a quick shot. With the extra attacker there is always a player open and therefore 1v1 dribbles are not necessary.

Defenders must coordinate such that one challenges the attacker with the ball while the second defender provides cover and is positioned at angles allowing the interception of the pass (closing passing lanes).

### Coach's Notes



## Technical Skill # 2: 2v2 Give & Go with Shot on Goal

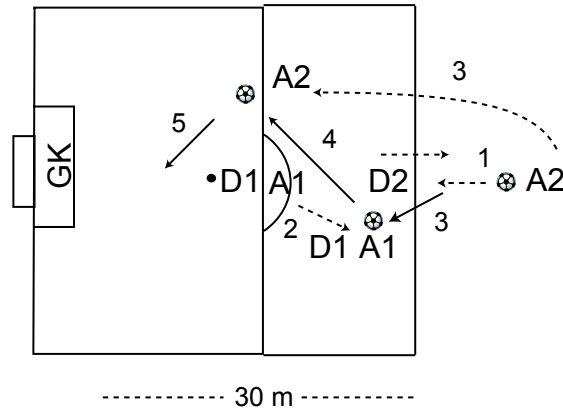

1. A2 dribbles towards D2 who is coming towards A1 to challenge.
2. A1 is making a diagonal run behind D2. D1 follows A1.
3. A2 passes to A1 and A2 immediately makes a wide run into space.
4. A1 rotates and makes a one touch pass into the run of A2.
5. A2 should be clear in the penalty box for a shot on goal.

### Coaching Points/Progression

Ask the defenders to allow the attackers to execute the passes and runs with success . Once they are successful, ask defenders to increase their pressure. A1 needs to rotate as they receive the ball to allow a one touch diagonal pass. This may be difficult and they may need to start with two touches. Two touches will make it more difficult as it allows the defender to close the space and block the pass.

Attackers must time their runs to get away from the defenders. This means delaying the run and reading the pass and then sprint away from defenders. A body fake in the opposite direction will help.

Have players work together the way they would in your game formation. This drill may appear tedious but it is critical for your attackers to synchronize with each other to get to a shot on goal. Set up as many areas as you can or rotate groups into the drill every 3-4 attempts.

### Coach's Notes



## Technical Skill # 3: 1v1 with Shot on Goal

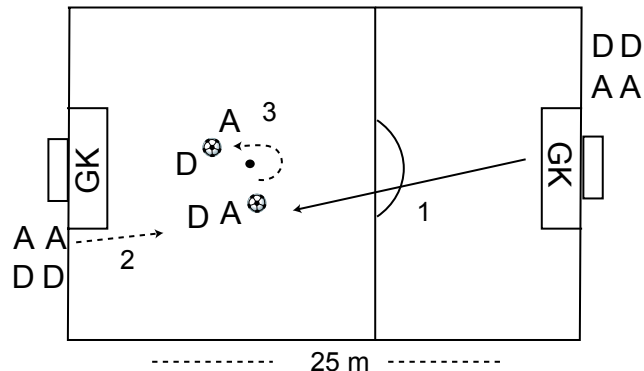

1. GK rolls or throws ball towards attacker (A) waiting at opposite goal.
2. A sprints to ball followed by defender (D)
3. Attacker receives ball and with first touch plays ball away from defender allowing attacker to turn and play 1v1 against defender. Attacker must finish with shot on goal.

After the 1v1 is completed, GK starts play on opposite goal.

### Coaching Points/Progression

The goalkeeper serving the ball out and the attacker must time the play to allow the attacker to accelerate away from the defender, forcing the defender to react to the play. One way may be for the attacker to sprint when the keeper starts his motion (leg or arm backswing).

Execution at high speed by the attacker is key to keep the defender off balance and allow a clean shot on goal from a good position.

Defenders need to react fast to prevent the attacker from turning with their first shot. After the attacker turns, defenders must "jockey" and time their tackle to the ball when the attacker pushes the ball away from their feet to initiate the 1v1 move.

### Coach's Notes



## Technical Skill # 4: Transition Play

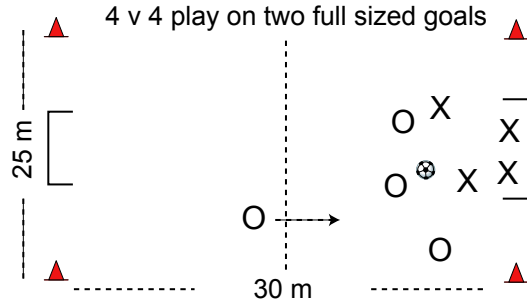

Two defenders (X) must be on goal line between posts before their two team mates can challenge attackers (O).

Attackers (O) must have all players in attacking half before they are allowed to score a goal.

After change of possession, O defends and two O's must sprint to goal line before the other two can challenge X's, who now attack and must have everyone across half before they can score a goal.

### Coaching Points/Progression

The set up in the diagram shows the end of the attack by O's. The last O was slow moving up the field preventing their team mates to score and having allowed two X's to be on the goal line. This allows the other two X's to challenge.

If X now wins the ball, they must break out of their half sprinting and pass the ball quickly. They need to get across the half line before two O's get on their own goal line. This allows them to either take a quick shot or to set up a 4v2. The X furthest back (likely one of the two who were in goal) must let his team mates know when they can go for goal (i.e. last X across half).

Defenders need to sprint back and the two sprinting to their own goal line must let team mates know who is sprinting back and when they get into the goal so that the other two defenders can now challenge. This is a physically demanding drill and coach must encourage speed.

### Coach's Notes



## Technical Skill # 5: 1 v 1

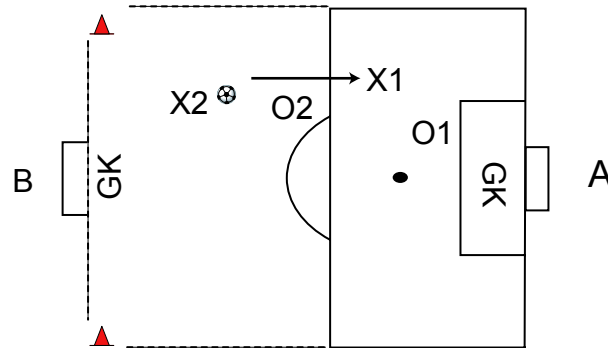

X's attack goal A and O's attack goal B.

- X2/O2 and X1/O1 stay in their own half.
- X2 passes ball to X1 who now plays 1v1 against O1 on goal A.
- If O1 wins ball, O1 passes to O2 who plays 1v1 against X2.

If goal is scored, ball goes out of play, GK restarts play by throwing ball in opposite half to attacking players.

### Coaching Points/Progression

The field of play is twice the size of the penalty area.

In the diagram, X2 just won the ball from O2. It is important for X1 to move into a space to allow a quick and safe pass from X2. This could be a short pass to feet, or, X1 could fake a move to one side opening space on the other side of the field. X2 then passes into space and X1 quickly turns and collects the ball. While the 1v1 is going on in one half, the attacker who would next get the ball in the other half must stay with the play and anticipate where they might get the ball. At the same time they want to move to create space between them and the defender. This may be a coaching challenge since players not involved in the play tend to be stationary. Remind players that in a game they would want to move into spaces and lose their defender.

The faster the play into the other half the better the chance for a quality scoring chance.

### Coach's Notes



## Technical Skill # 6: 4v4 Flank Attack

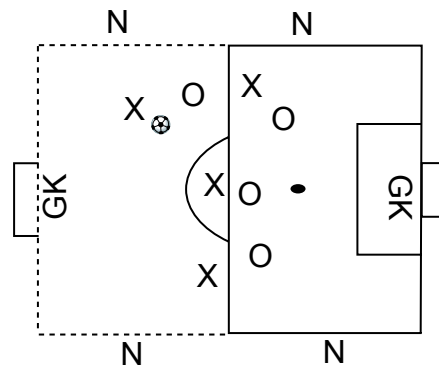

Set up field twice the size of penalty box.

Play 4 v 4 with 4 neutral players (N) positioned along sidelines. Team in possession can use neutral players who must play a cross or pass back to the team that played the ball out to them.

Rotate teams through neutral positions every 5 minutes.

### Coaching Points/Progression

This is an excellent drill to practice stretching the defense by switching the point of attack quickly. The neutral players are on the team that passes the ball out to them. An example of stretching the defense is to play the ball out to a Neutral who immediately switches it across the entire field to the Neutral on the other side. This is followed by an immediate cross into the target areas. As the switching takes place, defenders will be drawn (at least in attention) to one side, providing opportunities for attackers to make runs into space for the final cross or pass. Ask teams to mix up playing wide with combining through the middle.

Upon change of possession, a pass to a Neutral (wide) will be very effective.

Put teams together based on how they will play together in a game. Employ the same tactics as in your formation, i.e. if playing zonal defense, do it in this drill as well.

### Coach's Notes



## Technical Skill # 7: 4v4 in Small Area

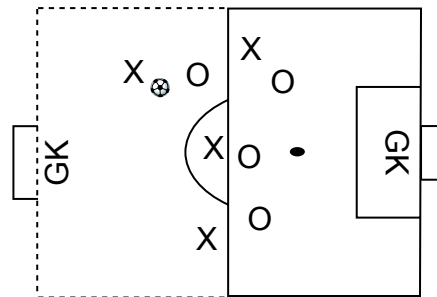

Set up field twice the size of penalty box.

X is the attacking team, O is the defending team.

X's can score into either goal, but must play ball across the half line first after an attempt on goal.

Play 5 minute games switching roles of teams (attackers/defenders).

### Coaching Points/Progression

The attacking team will be focused on the goal they are attacking. The key coaching point therefore is to encourage them to suddenly and quickly change direction and attack the opposite goal. This should put the defenders off balance and chasing the play, hence setting up a scoring chance.

After a goal, a save by the goalkeeper, or the ball going out of bounds, the goalkeeper in the defending half restarts play with a quick throw into the other half. Have extra balls in each goal to allow for continuous play.

Defenders need to challenge the ball and mark attackers closely. They will practice their reaction speed when the attackers change direction of play. They then need to sprint goalside of attackers before they can set up a clean shot.

### Coach's Notes



## Technical Skill # 8: Two Touch Shooting

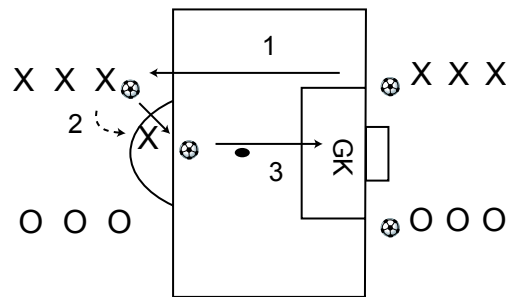

1. Players on goal line play a firm pass to players at the top of the box.
2. Players receive the pass and with their first touch set up a second touch shot. The first touch should be diagonally ahead.
3. The shot should be aimed at the far post.

Players who pass follow their pass and go to line at the top of box, shooters go to end of "passers" line.

### Coaching Points/Progression

The players on the goal line should not strike a stationary ball for the pass out. They need to slightly touch the ball ahead and strike a moving ball.

the pass out must be firm enough to safely reach the attacker and allow the attacker to control it properly with the first touch.

After the pass, the passer and the shooter need to sprint to the end of the opposite line to clear the field of play and allow the other line to get started. This should allow enough time for the goalkeeper to reset for the next shot.

Set up the drill on two goals to train both goalkeepers.

### Coach's Notes





## Technical Skill # 9: 1v2 Defending

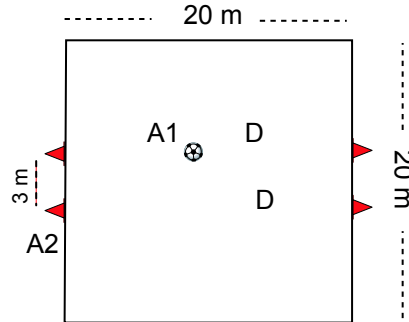

Attackers (A) and defenders (D) each defend a small goal.

A1 plays 1v2 against two defenders. A2 waits next to goal A's are defending.

A1 can attack defenders or pass back to A2. If A1 passes back, then A2 moves up and plays against D's while A1 takes spot A2 vacated.

If a defender wins the ball, that D now plays 1v2 against both A's while the second defender drops back next to goal D's are defending.

### Coaching Points/Progression

This is a challenging drill for the single attacker. To the attacker's advantage is the fact that there is no goalkeeper. This forces the second defender to close the "passing" lane from the attacker to the goal, in essence setting up a 1v1 followed by a second 1v1. It is important for the attacker with the ball to use the second attacker frequently. With appropriate, fast, and well timed runs the attackers must create spaces they can use to break through the defenders and score.

The defenders need to coordinate their play as well. Should the challenging (first) defender get beaten, they must immediately drop into the covering position and the previously covering defender must close the attacker extremely fast and challenge.

If attackers are not having any success at all, add an attacker to play 2v2 with the support player at the goal (There are 3A and 3D in the drill now).

### Coach's Notes



## Technical Skill # 10: Crossing and 2v1

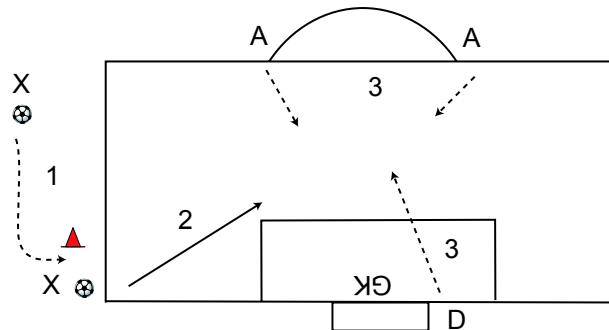

1. X dribbles along outside of penalty box, past cone,
2. X crosses ball towards top of box.
3. Attackers (A) win ball and play 1v1 against defender (D), who waits besides the goal until the cross is played in.

Rotate players such that everyone crosses, attacks and defends.

### Coaching Points/Progression

X needs to set up the cross with a final touch of the ball towards the target area so they can square their body into the direction of the cross. X needs to look up and select the target for the cross.

A's must communicate as to who will go for the ball.

Defender cannot leave the goal line until the ball is crossed, but then must close down the attacker quickly.

The crosses should vary in regards to the target area so that the defender needs to read the play and does not have the opportunity to anticipate.

### Coach's Notes

# Youth Competitive

## Fitness Drills



## Fitness Drill # 1: Pass and Sprint

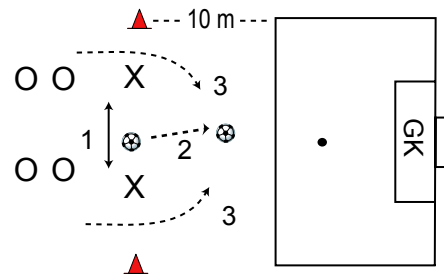

1. X's pass the ball back and forth to each other.
2. At random, one X passes ball slightly forward.
3. The pass is the command for the two O's to sprint around X's to win the ball and play 1v1 on goal.

### Coaching Points/Progression

Distance between X's should be approximately 5 m.

O's must be in ready position, ideally slightly bouncing on the balls of their toes.

The pass forward is about 7-8 m ahead and central between the X's, giving each O an equal chance of winning the ball. As soon as one O gets control of the ball, the other O defends. Game stops after a shot on goal or 15 seconds if O's are deadlocked.

To challenge O's after a while, the pass from X can be towards the side favouring one O and forcing the second O to sprint goalside of the ball to defend.

Set up several drills and rotate X's and O's every two minutes.

### Coach's Notes



## Fitness Drill # 2: 6 v 3

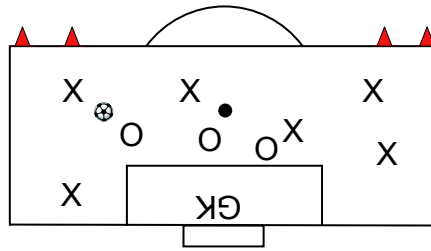

X's (6) play two touch soccer and attack large goal.

O's (3) defend large goal and after winning possession, counter attack through one of the two small (2 m wide) goals.

Play 3 games of 4 minutes rotating everyone through defense.

### Coaching Points/Progression

The defenders must send one player to challenge the attacker with the ball. The other two defenders must cover the attackers in the most dangerous scoring position (closest to goal).

Attackers need to pass the ball around quickly to open players, forcing defenders to move a lot to close down attackers with ball, therefore tiring the defenders.

Attackers need to take a shot from a central area as often as possible, but they should not forget to play the ball wide, stretching the defenders, and crossing it back in.

Once defenders gain possession, they must quickly pass the ball or clear it through a small goal. This means the attackers must immediately pressure the defender with the ball to regain possession before defenders can clear.

After a shot or goal, the play restarts with the attackers.

### Coach's Notes



## Fitness Drill # 3: Agility Sprint

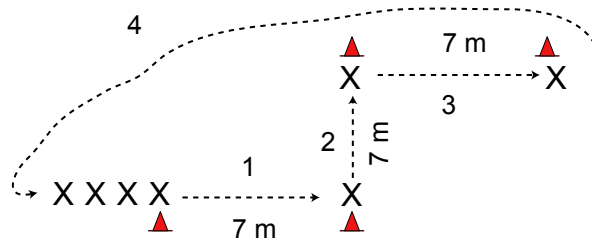

1. Hop with both legs up.
2. Sidestep shuttle run.
3. Explosive forward sprint
4. Jog back to end of line.

### Coaching Points/Progression

Set up as many drills as required to split your team into groups of 3 or 4.

Have groups compete against each other to determine fastest/slowest.

To challenge players more, increase the distance of the sprint (step 3) to a maximum of 20 m.

### Coach's Notes



## Fitness Drill # 4: Receive - Pass - Turn

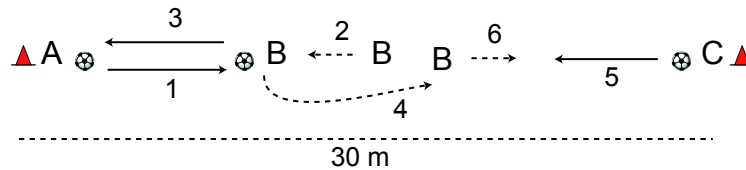

1. A passes ball towards B.
2. B attacks ball.
3. B plays one touch pass back to A.
4. After pass, B turns to face C.
5. C passes ball towards B.
6. B attacks ball.

Rotate each player for 3 minutes through position B

### Coaching Points/Progression

The first ball towards B must be a soft pass, forcing B to sprint to reach it before it stops. The distance from A to accomplish this should be ~ 5 m. This makes it a 20 m sprint for B after they turn to get to the next pass. You need to monitor this to make sure the player in the middle is asked to sprint for the full 3 minutes.

Player in the middle must play a controlled, high quality first touch back to the player at the end.

Depending on the fitness level of your players you may need to reduce the time in the middle to 60 seconds or 2 minutes. You can always increase the time at a later practice. You can also the distance between A and C.

This is a good test to determine the fitness level of your players.

### Coach's Notes



## Fitness Drill # 5: Reaction Sprint and 1v1

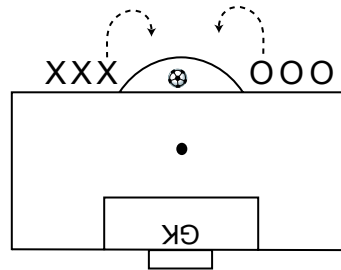

1. X and O face goal and jog backwards away from goal.
2. When X changes direction and sprints to ball, O reacts and tries to beat X to the ball.
3. X and O play 1v1 on goal.
4. After 1v1 is finished, X goes to end of line O, and O to line X.

### Coaching Points/Progression

X needs to jog back at least 3 m before they can change direction and sprint forward.

X is encouraged to fake out O to induce O to run forward. As long as X has not changed direction, O cannot attack the ball and must try to get back level with X.

Once the direction change is made and players try to win the ball, either player can score. X's with good fakes and speed should get in for a one time shot. On the other hand, excellent O's with outstanding reaction speed should be able to challenge X for the ball.

To add progression you can ask for players to jog back further before they are allowed to sprint forward. You can also set up the drill further away from the goal.

Set up several drills to keep everyone working hard.

### Coach's Notes





## Fitness Drill # 6: 3v1 with Crossing

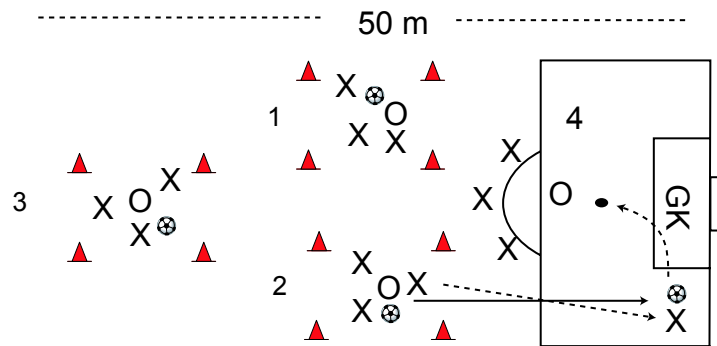

1. 3 groups play 3v1 inside 10m x 10m grid.
2. Groups 1 and 2 alternate sending a player to the corner with a pass.
3. Player crosses to group 4 who play 3v1 on goal.
4. Rotate groups every 3 minutes

### Coaching Points/Progression

In the 3v1 grids, players are encouraged to one - touch passing. If the defender touches the ball then the last attacker who passed it switches place with the defender.

Players in the group sending the ball to a corner for the cross must communicate to time the pass and run correctly. An attacker without the ball on the goal side of the grid must perceive if the attacker with the ball has a clear pass towards the corner. If they do, then the open player makes the run and gives a shout like "send" to call for the pass.

The cross should be to the target areas in front of the net and the three players trying to score must delay their runs to make sure the cross comes in front of them so they can run onto the ball for a shot/header on goal.

Players should be sent for goal every 15 - 20 seconds.

### Coach's Notes



## Fitness Drill # 7: Sprint and Score

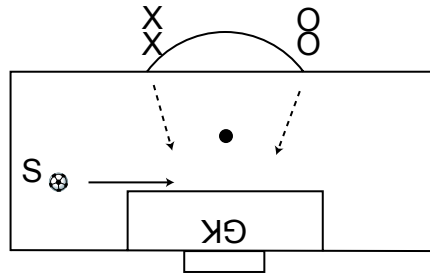

1. Server (S) throws ball straight across top of 6 yd box towards near post.
2. X and O sprint from top of penalty box, X to near post and O to far post. If X misses, O must finish with header/shot on goal.
3. Server varies ball on ground for kick, a sliding kick, header, or diving header.

### Coaching Points/Progression

Server must be accurate with the delivery of the ball.  
Server's throw should trigger the sprint by X and O.

Server should throw harder at times to intentionally miss the near post runner (X) and test the reaction speed and ability of O. Also, this way O's know that they will get opportunities. It is important to allow a few tries to get the timing between throws and runs right.

A variation is to bring S closer to the 6yd box and have X and O start the sprint and have the server throw after.

Goalkeepers should not be more than two steps off their line. This is a good reflex save drill for the goalkeepers. they should allow the shot/header but can close down the angle a bit.

### Coach's Notes



## Fitness Drill # 8: Dribble and Cross

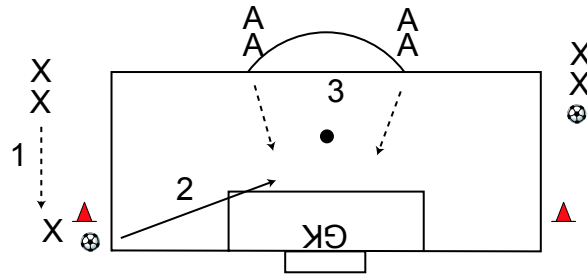

1. Wide players dribble past cone close to goal line.
2. Once past cone, they cross ball to target areas at the top of the 6 yd box, in line with goal posts.
3. Attackers (A) time their runs to the cross and finish on goal.

Alternate sides of crosses. Players (X) who crossed go to attacking line, players (A) that tried to score go to crossing line.

### Coaching Points/Progression

The player crossing must touch the ball around the cone so that player faces target before crossing the ball.

Attackers must delay their runs and time them to the cross to make sure they run onto the crossed ball, i.e. they must not overrun the ball.

The goalkeeper is allowed to come out and try to catch or punch the crossed ball. This will force accuracy, proper pace, and proper timing of runs. If done correctly, the goalkeeper should not be comfortable to come off the line because there isn't enough time.

### Coach's Notes



## Fitness Drill # 9: Sprint and 1v1

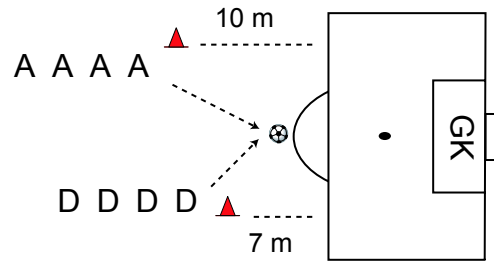

A sprints towards ball. That is the signal for D to react and also sprint to the ball.

The first player to touch the ball is the attacker and plays 1v1 against the other player who defends.

### Coaching Points/Progression

The objective is for the attackers (A) to get to the ball first, but only by fractions of a second. You may need to adjust the distances to make it work.

A's can use body fakes to get D's to run early. In that case D's have to get back to their starting position. During this instant, A can now make their "real" run. This should provide A with enough of a head start to get to the ball first.

If defender wins the ball, they can also finish with a shot on net. Allow no more than 15 seconds for the 1v1.

Adjust distance from goal to make players sprint further and hence increase the challenge.

### Coach's Notes



## Fitness Drill # 10: 4v4 in Penalty Box with Crosses

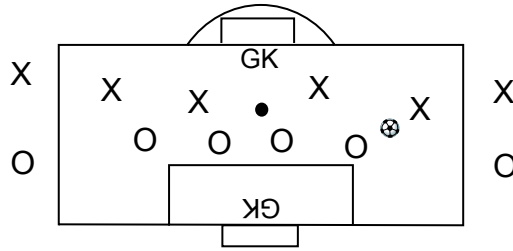

4v4 in penalty box on two full size goals with goalkeepers.

Teams can use players on side lines for crosses. Players outside box cannot challenge each other.

Players on side line can rotate into box to change place with a team mate.

### Coaching Points/Progression

Team in possession must be encouraged to take every opportunity to get off a shot on goal.

Passing should be one touch, two - touch maximum.

Remind players that they are in the penalty box and in a game situation they would take advantage of any small opening between players or even between legs of players to take a shot.

Inside the box, players should mark each other tightly. Using the outside players allows for time to make runs inside the box to get away from defenders.

Players inside the box can go outside any time changing place with the outside player thus adding elements of unpredictability and opening up spaces in behind them.

### Coach's Notes

# Youth Competitive

## Tactical Drills



## Tactical Drill # 1: 3v3 with Target Player

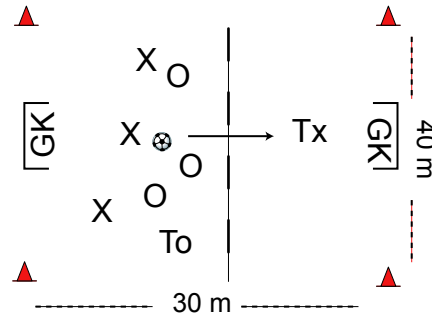

3 X v 3 O each team with target player To and Tx.

To and Tx stay in attacking half.

1 point for goal, 2 pts for goal after give & go with target player.

### Coaching Points/Progression

Target players must be differentiated from the rest of the team. The target player's role is to receive the ball from players in the defending half (break out pass) and to pass it back to a team mate. the target player is not allowed to score.

The defending team gets possession by winning the ball or after an attempt on net. After an attempt on goal the goalkeeper plays it out - the keeper may play it directly to the target player in the attacking half to speed up the transition.

The team that was attacking must get back to defending at top speed after loss of possession.

To add a challenge to the drill, allow teams to change target player "on the fly". A good strategy would be to leave the attacker that was closest to the opposing goal back as the new target.

### Coach's Notes



## Tactical Drill # 2: 7v7 into 4 Corners

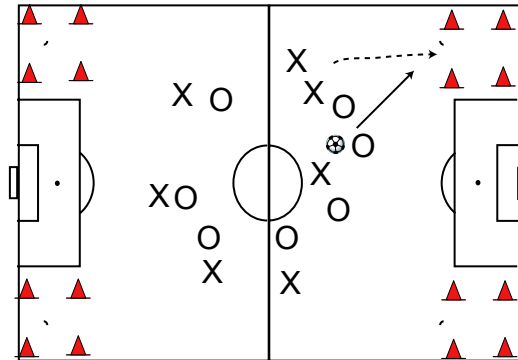

Team in possession scores point by passing to a player who has run into one of the four grids.

After a point, the other team gets the ball and must first play across half before scoring.

### Coaching Points/Progression

Teams will have a tendency to pick one of the squares and shift all their players towards that square. They may forget that at any time they can change the direction of attack to ANY of the four squares. The best way to accomplish this is to have at least one player make a run into space towards an unattended square. Two players can break to two different squares. The breaking players must be very vocal (loud shouts) to get the attention of their team mate with the ball - this is necessary due to the high level of focus of the players attacking a square. Quick changes of the point of attack are the key to success - in this drill and in a game.

if your players don't recognize the opportunity and don't make the runs, then you need to stop the drill, point out the opportunity and restart.

Once the defending team gains possession they need to break quickly towards an open square in the other half before the previously attacking team can get organized.

### Coach's Notes





## Tactical Drill # 3: 4+2 v 2+4

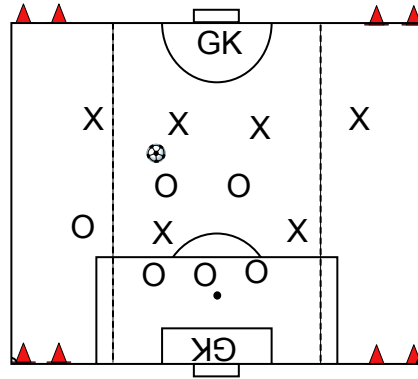

Field is divided into three zones.

X play freely v. O. Goal scored into regular nets = 1 pt

Goals scored into wide goals while at least one defender is trapped in opposite zone = 2pts.

### Coaching Points/Progression

The 4+2 team (X) is the attacking team and the 2+4 (O) team is the defending team.

The example shows the attacking team as the midfield (4) and strikers (2) of a flat 4-4-2 system, while the defending team is organized as a partial midfield (2) and the flat back (4) defense of a 4-4-2 system. You can change the formations and number of players to match your team's system of play more closely.

The key to this drill is to attack one of the side goals to draw the defenders into the corner and then to switch the play to the middle for a quick strike while a defender is caught wide. This puts pressure on the wide defender to hustle back to the middle.

You may need to adjust the position of the wide goals closer to the penalty box if the defenders never get back to the middle zone.

### Coach's Notes



## Tactical Drill # 4: 6v4 Pressing & Counterattack

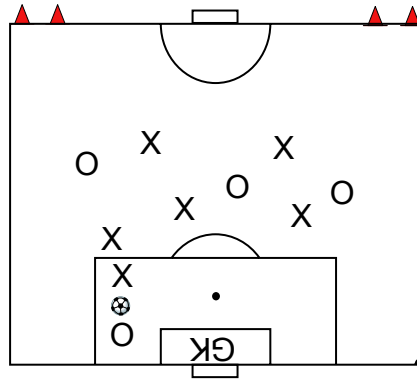

X's attack and O's defend regular goal.

After O's win ball they counter 2 goals at half.

Closest attacker X challenges O with ball and other X's support and close down passing lanes.

### Coaching Points/Progression

The challenge is for the defense (O) to organize themselves by challenging the attacker (X) with the ball and covering other X's. O's need to shift quickly as X passes the ball around. Communication amongst O's is critical.

Attackers (X) need to move the ball quickly to get O's out of position.

The key point of the drill is when O wins the ball. O's get the ball after a goal by X, after a failed attempt by X or after winning it through a regular challenge. O's want to play a quick release ball to a defender making a wide run to get the ball through the small goals. X's need to regain possession - after loss of the ball to O they need to immediately double up on the O with the ball, cover the other O's and use the sixth X to close down any passing lane.

The faster the runs, passes, and communication the more success both teams will have.

### Coach's Notes



## Tactical Drill # 5: Transition Play

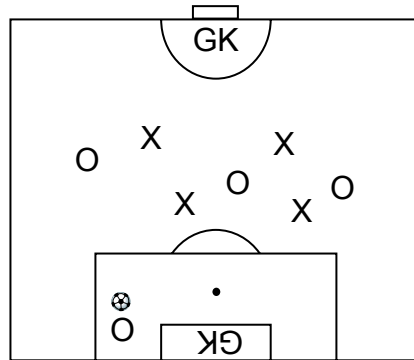

Play 4 v 4 in 5 minute games.

Both teams can score on either goal.

Teams cannot score on same goal twice in a row.

### Coaching Points/Progression

The key is for the team that is attacking one goal to realize they can reverse direction and attack the opposite goal. You may need to stop play and point out this opportunity if the teams do not. If they do break to the opposite goal then the defending team needs to react fast and transition to defend the other goal.

Teams also need to realize that if they win the ball while defending close to one goal, they can now score on that goal.

You can vary the drill by asking teams to play the ball across the half first after a change of possession.

Make up the teams as they would normally play in your system. Vary the numbers of each team if you want to practice certain formations, teams being outnumbered, etc.

### Coach's Notes



## Tactical Drill # 6: 6v6 Flank Attack

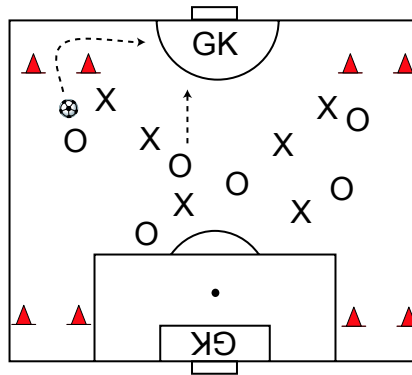

Teams must pass to team mate or dribble through one of the wide goals before they can cross on goal.

### Coaching Points/Progression

Goals can only be scored after a cross.

Teams can pass to a player running through a wide goal or they can dribble through it.

Encourage teams to attack one side and then with one or two passes switch the side of attack to take advantage of the space on the opposite side of the field. This will take at least two players to break to the other side. As soon as the defending team gains possession, they need to transition as fast as possible to counter through one of the wide goals. The previously attacking team needs to transition fast to now defend the small goals.

You can progress the drill by allowing teams to score goals without going through the wide goals first. In that case they cannot run two consecutive attacks through the middle.

### Coach's Notes



## Tactical Drill # 7: 4v4 + N Crossing

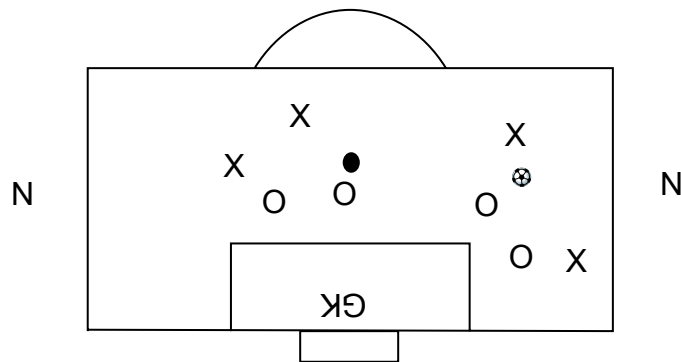

X and O play 4v4 game inside the penalty box.

Team in possession must play to either neutral player who must cross the ball to the team that played the ball out. If defending team wins ball, they now attack and play it out to neutral player.

### Coaching Points/Progression

After change of possession the ball must be played outside to a neutral player first.

Choose your teams according to your system of play. A suggestion is to have one team made up of 4 defenders, the other of two inside midfielders and two strikers with the neutrals being outside midfielders.

Challenge your players to a one touch passing game.

Ask Neutrals to vary their service including high crosses to near post, crosses to far post, passes back towards the top of the box. Play the ball to Neutrals at the top of the box, or send them for a run to the goal line. Make sure that the teams inside the box adjust their runs to the service from the Neutrals. Verbal and non-verbal communication is essential from all players.

### Coach's Notes



## Tactical Drill # 8: Crossing

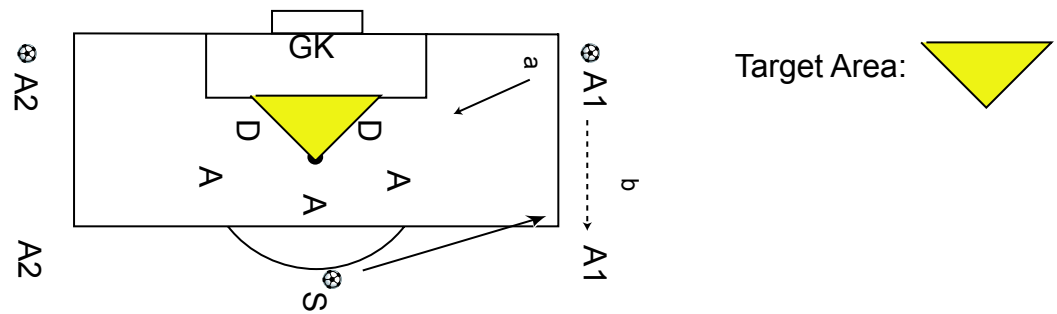

- A1 and A2 take turns crossing the ball into the penalty box. In the box, three attackers try to score against two defenders.
- If defenders win the ball, they play it to S outside the box. A1 and A2 now must sprint to top of box to receive a pass from S. They now dribble to goal line for a new cross.

### Coaching Points/Progression

Crosses must be aimed at the target area indicated. Each of the three attackers goes for one of the points of the target area,

Attackers must delay their runs. They should vary their runs by crossing over (diagonal runs) and moving before the cross.

Check the alertness of the crossing players to make sure they immediately sprint to the top of the box when the defenders gain possession. If defenders gain possession and are unable to get the ball to the server (S), then play restarts with the server. If attackers score or ball goes out of bounds, play restarts with a cross (a). Alternate crosses from left and right side.

A progression can be to allow the far side crosser (A2) to make a far post run when the ball is being crossed from the other side. Also, allow players to rotate positions "on the fly".

### Coach's Notes



## Tactical Drill # 9: 4v3 + Goalkeeper

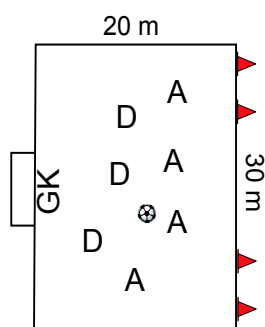

A's attack regular size goal with goalkeeper.

D's attack two small (3m wide) goals.

Play 5 x 3min with 1 min active rest between games.

### Coaching Points/Progression

The key tactical element for the attackers is to get into scoring position through one - touch passing and quick movements - then finishing with quick strikes on net.

The key tactical element for the defenders is to have one player challenging the attacker with the ball while the other two cover the other three attackers, close down passing lanes AND block shots.

Consider varying the drill to challenge attackers by playing 3v3 or 2v3 or to challenge the defenders by adding more attackers or removing defenders. Your decision will be driven by either balancing the success, providing success and encouragement to one group, or by emphasizing a particular game situation your team needs to improve upon.

### Coach's Notes



## Tactical Drill # 10: 4v4 with 3 Groups

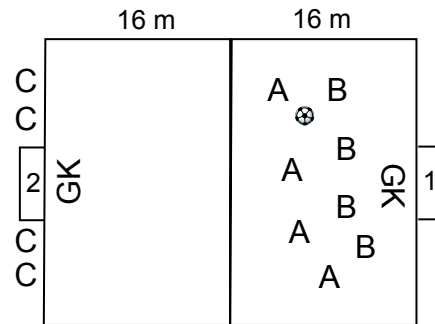

A's attack goal 1 defended by team B. If A scores or B gets possession, B now breaks to attack goal 2.

Team C comes out to defend goal 2 once B crosses the center line.

A drops to goal line of goal 1 and waits for C to attack.

### Coaching Points/Progression

Following the diagram, A may take a shot on goal and miss the net. A must immediately sprint to take their positions next to the goal, two players on either side of the goal post. There should be a supply of balls in each goal so that the goalkeepers restart the play quickly. As soon as A loses possession and sprints off, the goalkeeper plays a ball out to B who now transition to attack goal 2. If B wins possession during normal play, A sprints off and B attacks. C gets ready to attack B as soon as the FIRST B crosses the half line. This should encourage B to get all players across the half quickly. After B finishes the attack, they go to goal line and C now attacks A.

Once teams get the flow of the drill, allow the waiting defending team to challenge the team starting the attack as soon as they have the ball.

The keys are to have attacking team get off the field as fast as possible at the end of their play and to get to a shot on goal as quickly as possible through one-touch passes and runs into space.

### Coach's Notes



# Youth Competitive

## Scrimmages



## Scrimmage # 1: 6v6 - 1/2 Field

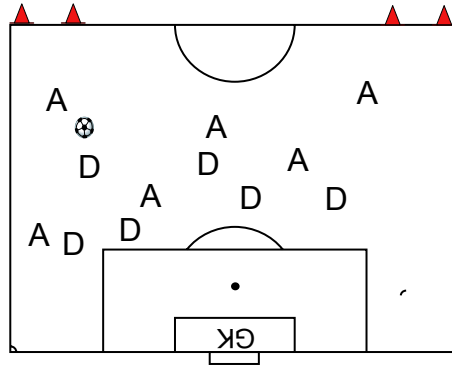

Attackers (A) play on goal.

Defenders counter through small goals.

10 min. games - rotate players.

### Coaching Points/Progression

The key point is to train the defense on playing the ball out wide after gaining possession. At the same time, this forces the attacking team to be aware and cover the entire width of the field after they lose possession.

You can adjust the number of players on each team and their positions based on:

- your system of play
- the issues you need to work on based on past game performance
- players you want to test in different positions.

A progression to this drill would be to allow the defenders to play the ball out to the center circle as well as through the wide goals.

### Coach's Notes



## Scrimmage # 2: Flank Attack

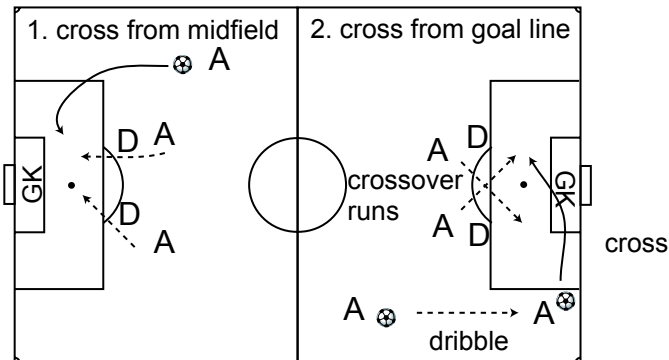

### Coaching Points/Progression

These are two separate scrimmages training two different positions from which to cross the ball.

Since the drill does not involve all players, have the players not involved rotate in after two crosses or have them do a separate technical drill.

Once you are satisfied that the crosses are coming in to the target area and that the runs are timed properly, you can progress the drill by adding players to each side first ultimately leading to a full field game. In this case, maintain the principle of the scrimmage by requiring that goals can only be scored from a cross.

This is a good drill to try out your substitutes. You can also count the number of goals scored for 10 attempts and challenge your team to improve in every set of 10 attempts.

### Coach's Notes



## Scrimmage # 3: 1v1 Defending in 7v7

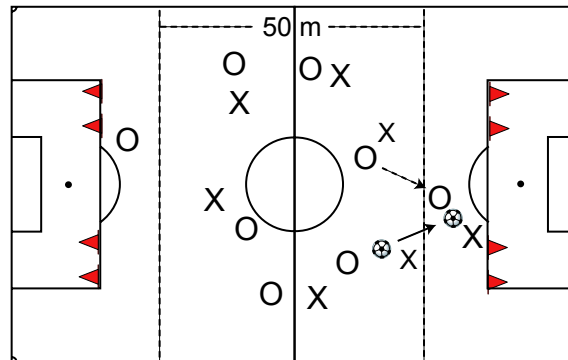

6v6 in a 50m wide zone in the middle of the field.

One player from each team is in their own defending zone.

Attackers pass ball to a team mate running into end zone and play 1v1 on either of two small goals. After attempt is complete, defender plays ball back to middle zone to a team mate.

### Coaching Points/Progression

The team in possession in the middle zone must quickly change the side of the field to draw the defender to one side. they then need to switch the play and send a player into the attacking zone on the opposite side. The waiting defender has to read the play and follow it.

Once the 1v1 is in play, it is important for the attacker to remember that there are two small goals they can score on. Quite often the 1v1 will be focused on one of the goals only. If that happens, stop the play and make your "coaching point".

Allow a maximum of 15 seconds for the 1v1. If the attacker doesn't score, the defender gets the ball and starts a counterattack by playing the ball into the middle to a team mate. Players in the middle must remain alert during the 1v1 to be in a position to receive an easy pass out from their defender. Progress by playing 2v1, etc. Allow the defender to switch with a player in middle.

### Coach's Notes



## Scrimmage # 4: 7v7 with GK Transition Play

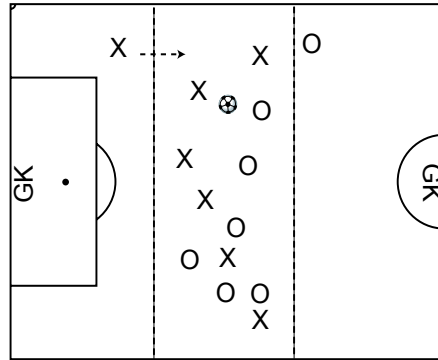

Divide half the field into 3 equal zones.

Team in possession must have all players at least in middle before they can score.

In own defending third only, teams play two touch soccer until ball is played out of defending zone.

### Coaching Points/Progression

All players can join the attack and enter the attacking third.

The key coaching point is that if the defense gains possession (by winning the ball, after a goal, after a missed attempt on goal), they must transition to attack and move everyone out of their defending third as soon as possible. Players holding on to the ball in their defending third must be encouraged to play one or two touch and do it quickly.

Teams need to communicate so that the attackers know when the last defender is in the middle so they can score.

You can vary the number of players on each team and assign positions based on your system of play. This is a great drill to teach your defenders to move up the field quickly.

### Coach's Notes



## Scrimmage # 5: Transition Play

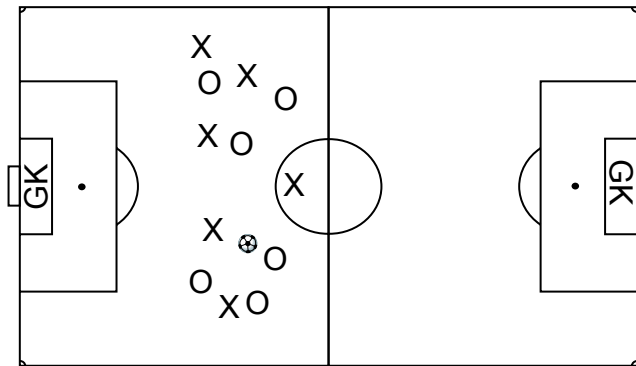

Teams play 6v6 in one half of the field, keeping possession of the ball.

On command by coach, team in possession breaks across half and tries to score.

The other team tries to win the ball and score on the same goal.

Award 2 pts for goal by breaking team, 1 pt for goal by the defending team.

### Coaching Points/Progression

This is a reaction drill for both teams. We suggest the coach uses the blow of a whistle to indicate the time the team in possession breaks across the half. Teams in possession should play according to your style - one touch, two touch, supporting runs, 1v1, etc.

The key is for the coach to vary the time allowed for the team in possession before blowing the whistle. Some suggestions:

- after extended play, maximum of 30 seconds
- immediately after a change of possession

Make sure the teams don't simply play within a narrow band of the half line anticipating the command to break out. They should switch play, use support players so that they will be in position for a clear break setting up an "easy" goal.

### Coach's Notes



## Scrimmage # 6: 4v4 & 3v2

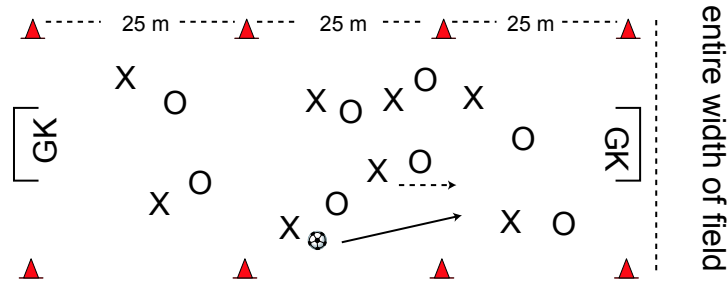

4v4 in middle sections: team in possession tries to send a player into either end zone to set up a 3v2 on goal.

After an attempt on goal the GK restarts play by throwing a ball back into the middle zone.

### Coaching Points/Progression

Each team has eight players, 4 in the middle and 2 in each of the end zones. Make up your teams according to your system of play (attacking vs defending players) or your coaching objective for the day (starters vs. substitutes; defenders + midfield v attackers + midfield).

The key coaching point is to encourage the players in the middle zone to recognize that they can attack either end zone. If they get bogged down on one side, one of their players should call for a change of direction. That player could be one of the end zone players because they have the best view of the entire field.

Progress the drill by allowing end zone players to freely interchange with middle zone players. The important factor is to maintain the "shape" of the drill and have the appropriate number of players in each zone. Once defenders win the ball, they play it to a team mate in the middle.

### Coach's Notes



## Scrimmage # 7: 7v7 Flank Attack

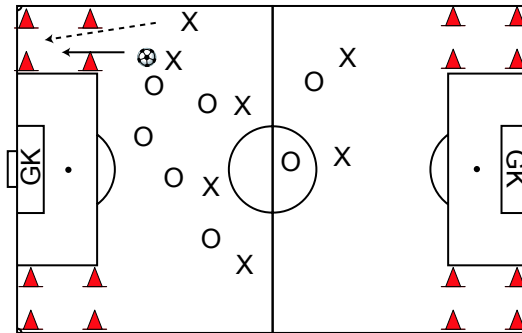

Both teams can score on either goal after passing the ball to a team mate in one of the corner squares.

Players cannot be challenged in the square.

Teams must play ball across the center of the field before they can score again.

### Coaching Points/Progression

On change of possession (goal, winning the ball, ball out of play) the team that was defending now transitions quickly to get the ball across the half. Once across the half, they have the choice to attack ANY of the four squares. if you notice that they never reverse direction to attack the goal they just defended, then stop play and point out the missed opportunity. They need to realize that reversing direction against the run of the team chasing them will open up the most space.

Progress the drill by allowing players in the square to be challenged by the defending team.

Consider having more players on one of the teams to challenge the defense or to provide a "success" for the offense. This depends on your motivational emphasis at the time of practice.

### Coach's Notes





## Scrimmage # 8: 7v7 with Crossing

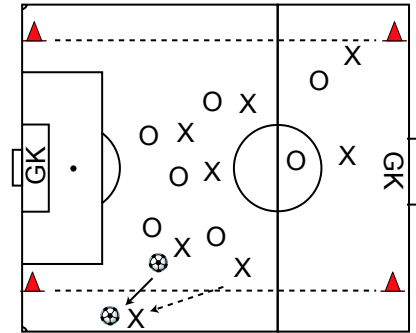

Two teams play 7v7 two- touch soccer on 3/4 field.

Cones along each side mark a free "crossing" lane.

Team in possession can pass the ball to a player running into crossing lane, where they cannot be challenged.

Teams get 2pts for a goal after a cross and 1 pt for a goal through middle.

### Coaching Points/Progression

Each team attacks one goal and defends the other.

Observe how teams vary the attack between playing wide and through the middle. If they are not balanced to your preference, then stop and make the "coaching point".

Add complexity by asking teams to send two players into the crossing lanes where they must execute an overlapping run.

Vary the drill by allowing 2 attackers and 1 defender into the crossing lanes.

Ask the teams to switch the point of attack from one crossing lane to the other through a long pass across the width of the field.

### Coach's Notes



## Scrimmage # 9: 8v8

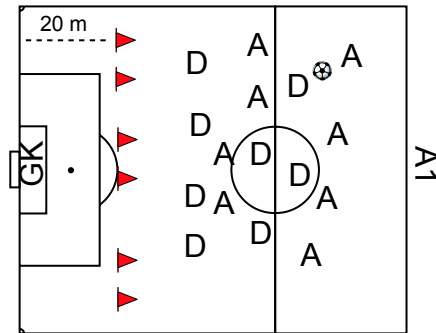

Attackers (A) must dribble through one of small (3m) goals before they can score.

The player who dribbled through cannot be challenged and gets a free shot on goal.

If defenders win the ball, they play it out to A1 who restarts the attack.

### Coaching Points/Progression

Defenders will have a tendency to play a "goalie" in each of the small goals. If that happens, you can make the point for them in several ways;

- remind them that they wouldn't play defense in a game that way, marking "space"
- making the small goals wider such that a player on the line isn't effective anyways
- allowing the attackers to pass through the small goals
- reward defenders with 2 points for each pass to A1 thus using competition to change behaviour
- simply asking them they must be in the play and cannot stay in goal (enforce a rule)

Encourage the attacking team to "load" one side of the field and attack one wide goal and then quickly switch play to the opposite side. Attacking the center goal with "numbers" is also effective because the attackers now have a choice of switching to either wide goal.

### Coach's Notes



## Scrimmage # 10: 5v4

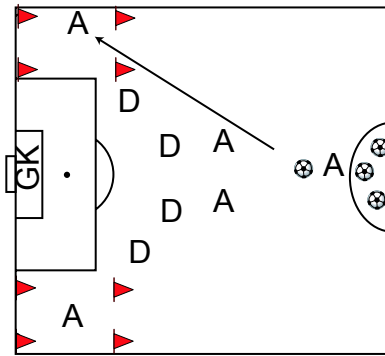

(A) near center circle plays a long ball to A in one of the wide zones.

Once A receives the ball, defenders (D) can challenge.

If D's win ball, they clear it past half. A's reset and start a new attack.

### Coaching Points/Progression

The key is to stretch the defense by forcing the initial play to go wide. Once that is accomplished the play becomes a regular 5v4. However, having stretched the defense, you can encourage your players to quickly (one touch passing, quick runs) play the ball into the middle to use gaps in the defense for a quick strike on goal.

Depending on the success of the attackers and your coaching objective, vary the number of players on each team. If attackers initially have difficulty playing the ball back out of a square, implement a rule of "no-challenge" in the square.

Ensure that all attackers are in motion at all times making "decoy" runs, run deep and check back, to distract defenders and open up the play for an easy pass to a corner.

Player A must release the ball within 3 seconds, so the attackers must make decisions fast.

### Coach's Notes